

1

The History of Vacuum Science and Vacuum Technology

Dr. Karl Jousten

Physikalisch-Technische Bundesanstalt, Vacuum Metrology, Abbestr. 2-12, 10587, Berlin, Germany

In old Greece, before the time of Socrates, the philosophers searched for the constancy in the world, that is, what is behind the daily experience. The Greek philosopher *Democritus* (circa 460 to 375 BC) (Figure 1.1) assumed that the world was made up of many small and undividable particles that he called *atoms* (atomos, Greek: undividable). In between the atoms, *Democritus* presumed empty space (a kind of microvacuum) through which the atoms moved according to the general laws of mechanics. Variations in shape, orientation, and arrangement of the atoms would cause variations of macroscopic objects. Acknowledging this philosophy, *Democritus*, together with his teacher *Leucippus*, may be considered as the inventor of the concept of vacuum. For them, the empty space was the precondition for the variety of our world, since it allowed the atoms to move about and arrange themselves freely. Our modern view of physics corresponds very closely to this idea of *Democritus*. However, his philosophy did not dominate the way of thinking until the sixteenth century.

It was *Aristotle's* (384 to 322 BC) philosophy that prevailed throughout the Middle Ages and until the beginning of modern times. In his book *Physica* [1], around 330 BC, *Aristotle* denied the existence of an empty space. Where there is nothing, space could not be defined. For this reason, no vacuum (Latin: empty space, emptiness) could exist in nature. According to his philosophy, nature consisted of water, earth, air, and fire. The lightest of these four elements, fire, is directed upward, whereas the heaviest, earth, downward. Additionally, nature would forbid vacuum since neither *up* nor *down* could be defined within it. Around 1300, the medieval scholastics began to speak of a *horror vacui*, meaning *nature's fear of vacuum*. Nature would abhor vacuum and wherever such a vacuum may be on the verge to develop, nature would fill it immediately.

Around 1600, however, the possibility or impossibility of an evacuated volume without any matter was a much-debated issue within the scientific–philosophical community of Italy, and later in France and Germany as well. This happened at the time when the first scientists were burnt at the stake (*Bruno* in 1600).

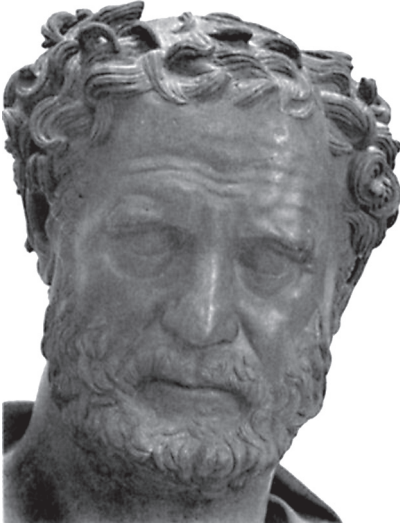

Figure 1.1 *Democritus*. Bronze statue around 250 BC, National Museum in Naples.

In 1613, *Galileo Galilei* in Florence attempted to measure the weight and density of air. He determined the weight of a glass flask containing either compressed air, air at atmospheric pressure, or water. He found a value of $2.2 \text{ g } \ell^{-1}$ for the density of air (the modern value is $1.2 \text{ g } \ell^{-1}$). This was a big step forward: air could now be considered as a substance with weight. Therefore, it could be assumed that air, in some way, could also be removed from a volume.

In 1630, *Galilei* was in correspondence with the Genoese scientist *Baliani* discussing the water supply system of Genoa. *Galilei* argued that, for a long time, he had been aware of the fact that the maximum height of a water column in a vertical pipe produced by a suction pump device was about 34 feet. *Baliani* replied that he thought this was due to the limited pressure of the atmosphere!

One can see from these examples that in Italy in the first half of the seventeenth century the ground was prepared for an experiment, which was performed in 1640 by *Gasparo Berti* and in 1644 by *Evangelista Torricelli*, a professor in Florence. The *Torricelli* experiment was bound to be one of the key experiments of natural sciences.

Torricelli filled a glass tube of about 1 m in length with mercury. The open end was sealed with a fingertip. The tube was then brought to an upright position with the end pointing downward sealed by the fingertip. This end was immersed in a mercury reservoir and the fingertip removed so that the mercury inside the tube was in free contact with the reservoir. The mercury column in the tube sank to a height of 76 cm, measured from the liquid surface of the reservoir. Figure 1.2 shows a drawing of the *Torricellian* apparatus.

The experiment demonstrated that the space left above the mercury after turning the tube upside down was in fact a vacuum: the mercury level was independent of the volume above, and it could be filled completely with water

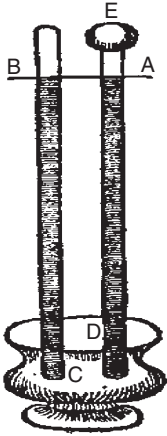

Figure 1.2 *Torricelli's* vacuum experiment in 1644. The level AB of mercury in both tubes C and D was equal, independent of the size of the additional volume E in tube D. (From Ref. [2].)

admitted from below. This experiment was the first successful attempt to produce vacuum and subsequently convinced the scientific community. An earlier attempt by *Berti* who used water was less successful.

In 1646, the mathematician *Pierre Petit* in France informed *Blaise Pascal* (Figure 1.3) about *Torricelli's* experiment. *Pascal* repeated the experiment and, in addition, tried other types of liquid. He found that the maximum height was exactly inversely proportional to the used liquid's density. *Pascal* knew the equally famous philosopher *Descartes*. During a discussion in 1647, they developed the idea of air pressure measurements at different altitudes using a *Torricellian* tube.

Pascal wrote a letter to his brother-in-law *Périer* and asked him to carry out the experiment on the very steep mountain *Puy de Dôme*, close to *Périer's* home.



Figure 1.3 Portrait of *Blaise Pascal*.

Périer agreed and on September 19, 1648 [3], he climbed the *Puy de Dôme* (1500 m) accompanied by several men who served to testify the results, which was common practice at the time. They recorded the height of the mercury column at various altitudes. From the foot to the top of the mountain, the difference of the mercury column's height was almost 8 cm and *Pascal* was very pleased: the first successful pressure measurement had been carried out! *Torricelli*, however, never enjoyed the triumph of the experiment based on his invention: he had died a year before.

Despite these experiments, the discussion between the *plenists* (no vacuum is possible in nature) and the *vacuists* (vacuum is possible) continued. One of the leading vacuists was *Otto von Guericke*, burgomaster of Magdeburg in Germany from 1645 to 1676 (Figure 1.4).

He was the first German scientist who gave experiments a clear priority over merely intellectual considerations when attempting to solve problems about nature.

Around 1650, *Guericke* tried to produce a vacuum in a water-filled, wooden cask by pumping out the water with a pump used by the fire brigade in Magdeburg. Although the cask was specially sealed, the experiment failed: the air rushed into the empty space above the water through the wood, developing a chattering noise. Consequently, *Guericke* ordered to build a large copper sphere, but when the air was pumped out, the sphere was suddenly crushed. *Guericke* correctly recognized atmospheric pressure as the cause and ascribed the weakness of the sphere to the loss of sphericity. The problem was solved by constructing a thicker and more precisely shaped sphere. After evacuating this sphere and leaving it untouched for several days, *Guericke* found that the air was seeping into the sphere, mainly through the pistons of the pump and the seals of



Figure 1.4 Portrait of *Otto von Guericke* in 1672. Engraving after a master of *Cornelius Galle the Younger*. (From Ref. [4].)

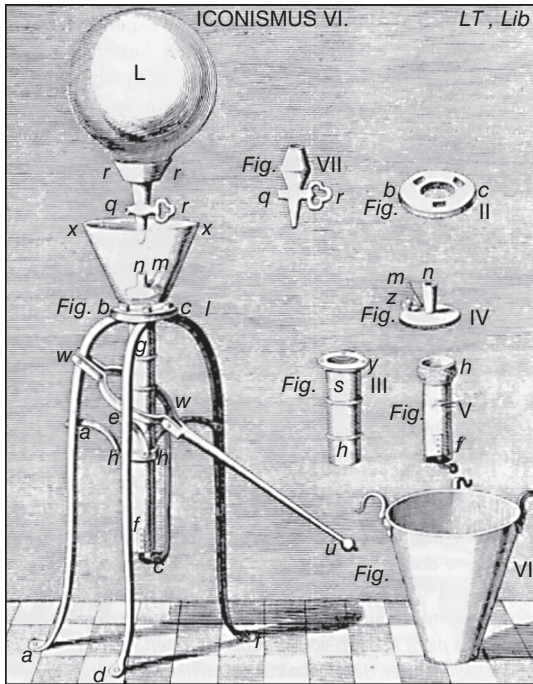

Figure 1.5 Guericke's air pump no. 3. Design for Elector Friedrich Wilhelm, 1663. (From Ref. [4].)

the valves. To avoid this, he constructed a new pump where these parts were sealed by water, an idea still used in today's vacuum pumps, but with oil instead of water.

Guericke's third version (Figure 1.5) was an air pump, which pumped air directly out of a vessel. These pumps were capable of producing vacua in much larger volumes than *Torricellian* tubes.

The word *pump* is still used for today's vacuum pumps, although they are actually rarefied gas compressors. This is due to the origin of the vacuum pump: the water pump used by the fire brigade in Magdeburg.

Guericke was also a very successful promoter of his own knowledge and experiments, which he used to catch attention for political purposes. In 1654, he performed several spectacular experiments for the *German Reichstag* in Regensburg. The most famous experiment demonstrating the new vacuum technique was displayed in Magdeburg in 1657.

Guericke used two hemispheres with a diameter of 40 cm, known as the *Magdeburg hemispheres* (Figure 1.6). One of the hemispheres had a valve for evacuation, and between the hemispheres, Guericke placed a leather ring soaked with wax and turpentine as seal. Teams of eight horses on either side were just barely able to separate the two hemispheres after the enclosed volume had been evacuated.



Figure 1.6 Painting of *Guericke* showing his experiment with the hemispheres to the German emperor, *Kaiser Ferdinand III*. (From Ref. [4].)

News of *Guericke's* experiment spread throughout Europe and his air pump can be considered as one of the greatest technical inventions of the seventeenth century, the others being the telescope, the microscope, and the pendulum clock.

The new vacuum technology brought up many interesting experiments. Most of them were performed by *Guericke* and *Schott* in Germany, by *Huygens* in the Netherlands, and by *Boyle* and *Hooke* in England.

Guericke showed that a bell positioned in a vacuum could not be heard; a magnetic force, however, was not influenced by the vacuum. Instead of metal, he often used glass vessels in order to make the processes in vacuum visible. For this, he used glass flasks from the pharmacist. These were called *recipients*, a word still used today for vacuum vessels. *Guericke* put a candle in a glass vessel and found that the candle extinguished slowly as evacuation proceeded. *Huygens* suspended a lump of butter in the center of a vacuum jar and, after evacuation, he placed a hot iron cap over the jar. In spite of the hot jar, the butter did not melt. Animals set into vacuum chambers died in a cruel manner. *Guericke* even put fish in a glass vessel, half filled with water. After evacuating the air above and from the water, most of the fish swelled and died.

Noble societies of the seventeenth and eighteenth century enjoyed watching experiments of this kind for amusement (Figure 1.7).

However, scientific experiments were performed as well during the early days of vacuum. *Huygens* verified that the free fall of a feather in a vacuum tube was



Figure 1.7 "Experiment on a bird in the air pump," 1768, by *Joseph Wright*, National Gallery, London. A pet cockatoo (top center) was placed in a glass vessel and the vessel was evacuated. The lecturer's left hand controls

the plug at the top of the glass globe. By opening it, he saves the life of the already dazed bird. The man below the "experimenter" stops the time until the possible death of the bird.

exactly equal to that of a piece of lead. *Boyle* found that the product of volume and pressure was constant, while *Amontons* in France showed that this constant was temperature-dependent (1699).

In 1673, *Huygens* attempted to build an internal combustion engine using the pressure difference between the atmosphere and a vacuum to lift heavy weights (Figure 1.8). Gunpowder, together with a burning wick, is placed in container *C*, arranged at the lower end of cylinder *AB*. The violent reaction of the gunpowder drives the air out of the cylinder through the wetted leather tubes *EF*. Cylinder *AB* cools down and produces a vacuum. The tubes *EF* then flatten and seal, and the atmospheric pressure drives down piston *D*, thus lifting weight *G*.

During the experiments, the importance of carefully cleaned materials became obvious and it was realized that the quality of pumps would have to be improved. Engineering improvements by *Hooke*, *Hauksbee* (1670–1713), and others followed. Somewhat later, the Englishman *H. A. Fleuss* developed a piston pump that he named *Geryk* in honor of *Otto von Guericke*.

However, it was not until 1855 that significantly better vacua could be produced using a pump designed by *Geissler* in Germany. *Sprengel* improved this pump in 1865 and 1873 (Figures 1.9 and 1.10), which used *Torricelli's* principle. Ten kilograms of mercury had to be lifted up and down by hand for a pump speed of about $0.004 \ell \text{ s}^{-1}$. About 6 h of pumping action was required to

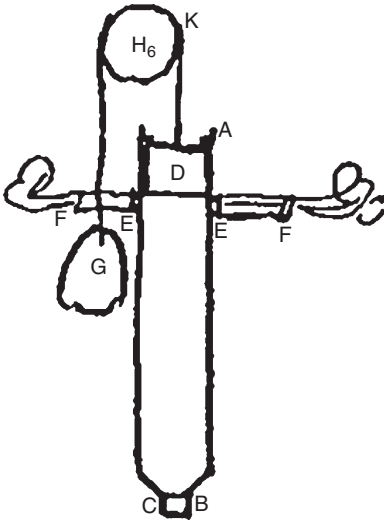

Figure 1.8 Huygens' explosion motor. After the explosion of gunpowder in container C, the temperature drops creating vacuum that lifts weight G. (From Ref. [3].)

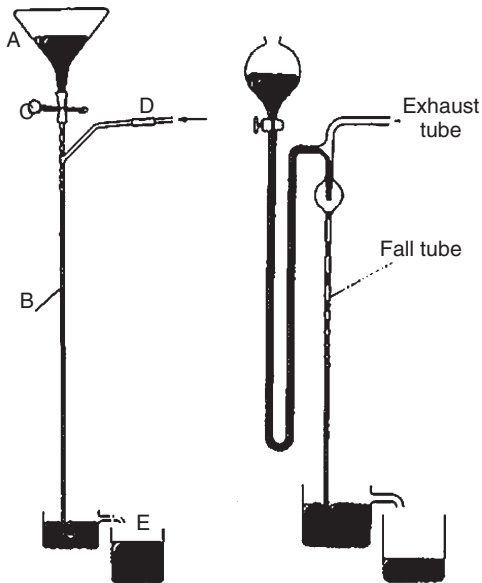

Figure 1.9 Sprengel's first mercury pumps of 1865. A falling mercury droplet formed a piston that drove the air downward (suction ports at D and "exhaust tube"). Later, Sprengel improved the pump by adding a mechanism to recover the mercury. (From Ref. [5].)

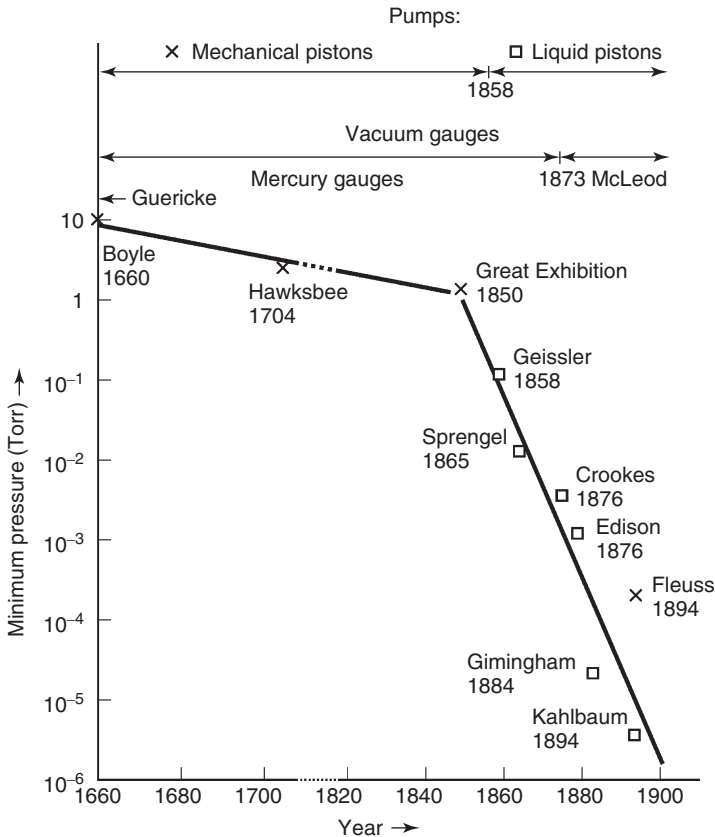

Figure 1.10 Progress in lowest generated and measured pressures in vacuum from 1660 to 1900. (Data from Ref. [6].)

evacuate a vessel of 6ℓ from 0.1 mmHg (13 Pa) to about $2 \times 10^{-5} \text{ mmHg}$ ($2.7 \times 10^{-3} \text{ Pa}$)! With these pumps, for the first time, the high-vacuum regime became available. In 1879, *Edison* used them in his *Menlo Park* to evacuate the first incandescent lamps (Figure 1.11).

The early scientists who produced vacuum still had no clear definition of a vacuum. They had no idea that air could consist of atoms and molecules, which in part are removed to produce a vacuum. Until 1874, the *Torricellian* tube was the only instrument available for measuring vacuum, and limited to about 0.5 mmHg (67 Pa). The idea of vacuum was still quite an absolute (present or not) as in the *Aristotelian* philosophy but it was not accepted as a measurable quantity. The gas kinetic theory by *Clausing*, *Maxwell*, *Boltzmann*, and others as well as the invention of the gauge by *McLeod* (1874), however, showed that vacuum indeed was a measurable physical quantity.

The *McLeod* gauge (Figure 1.12), still applied in a few laboratories today, uses *Boyle's* law. By compressing a known volume of gas by a known ratio to a higher

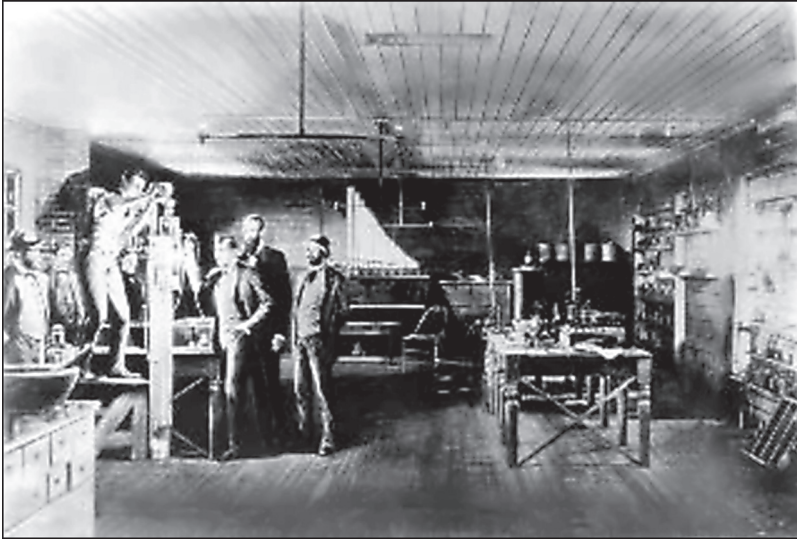

Figure 1.11 Edison's production of incandescent lamps in *Menlo Park* in 1879. The man standing elevated pours mercury into a *Sprengel* pump (Figure 1.9) to evacuate an incandescent lamp.

pressure, which can be measured using a mercury column, the original pressure can be calculated.

Huygens' idea of using the pressure difference between the atmosphere and a vacuum to build an engine was continued by *Thomas Newcomen* in the eighteenth century. He used condensed steam to create vacuum. *Newcomen's* engines were broadly used in England to pump water from deep mine shafts, to pump domestic water supplies, and to supply water for industrial water wheels in times of drought. His machines predate rotary steam engines by 70 years.

Another exciting development in the history of vacuum technology took place when *atmospheric railways* were constructed in England during the mid-nineteenth century. Since steam locomotives at the time were rather unreliable, dirty, noisy, heavy, and not able to face steep gradients, a group of imaginative engineers conceived a plan to build clean, silent, and light trains driven by the force between the atmosphere and a vacuum on the surface of a piston placed between the rails.

In 1846, *Brunel* built such a system on the South Devon coast of England (Figure 1.13).

A continuous line of a cast iron tube was arranged centrally between the rails. The pressure difference of the external atmosphere on its rear and the rough vacuum on its front surface propelled a tightly fitted piston inside the tube. Huge stationary pumps placed in about 5 km intervals along the track generated the vacuum. The underside of the first railway coach was connected to a frame forming the rear end of the piston. Along the top of the tube was a slot closed by

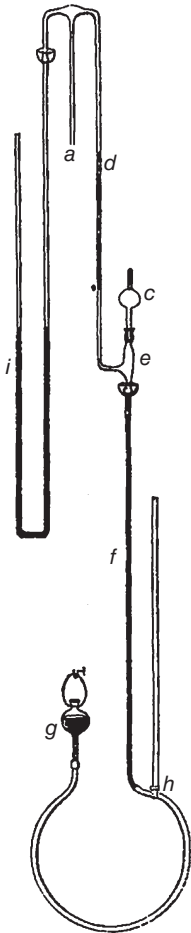

Figure 1.12 Original *McLeod* vacuum gauge [7]. (a) Measuring port; (b) simple siphon barometer; (c) glass bulb with a volume of 48 ml and a volume tube at the upper end having identical diameter as the measuring tube (d); (f) vertical 80 cm long

tube; and (g) reservoir of mercury. As soon as the mercury is lifted to the level of (e), the gas in (c) is compressed developing a height difference between (d) and the tube above (c) according to the volume ratio.

a longitudinal airtight valve, consisting of a continuous leather flap reinforced with iron framing.

An average speed of 103 km h^{-1} over 6 km was reported for these trains, which was breathtaking at the time. However, atmospheric railways did not prevail. Accidents with starting trains, the lack of control by the engineer on board, and the inefficiency of the longitudinal valve (e.g., rats ate through the leather sealing), among other reasons, contributed to their demise.

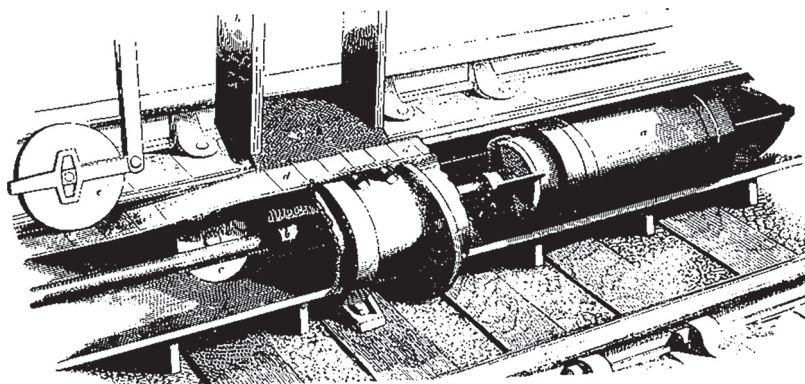

Figure 1.13 Drawing of the vacuum traction tube to propel an atmospheric railway. Piston (a) slides forward due to the action of a vacuum pump positioned in front of (to the right of) the piston. (b) connects the piston with the leading wagon of the train. Wheel (c) lifts and opens the longitudinal valve (d) while wheel (e) closes it. (From Ref. [8].)

The large advances in physics in the second half of the nineteenth century are almost unthinkable without the aid of vacuum technology. *Hauksbee* already discovered gas discharges at the beginning of the eighteenth century. Significant progress, however, was only possible after the invention of the *Geissler* pump in 1855. Three years later, *Plücker* found that the glow of the glass wall during a gas discharge shifts when a magnetic field is applied. In 1860, *Hittorf* discovered that the rays from a cathode produce a very sharp shadow if an object is placed in between the cathode and a glass. Many scientists continued research on cathode rays, which finally led to the discovery of the electron as a component of the cathode rays by *J. Thomson* in 1898.

In 1895, *Röntgen* reported that when a discharge is pumped to less than 1 Pa, a highly penetrating radiation is produced capable of passing through air, flesh, and even thin sheets of metal. He named the beams X-rays.

In 1887, *Hertz* discovered the photoelectric effect under vacuum. In 1890, *Ramsay* and *Rayleigh* discovered the noble gases. All these experiments helped to understand the nature of vacuum: the increasing rarefaction of gas atoms and molecules. At the time, it became clear that any matter in nature consists of atoms.

In 1909, *Knudsen* [9] published a comprehensive investigation on the flow of gases through long and narrow tubes. He divided this flow into three regimes: the molecular regime at very low pressures, where the particles are so dilute that they do not interact with each other but only with the surrounding walls, the viscous regime at higher pressures, where the motion of particles is greatly influenced by mutual collisions, and an intermediate regime. This publication can be considered as the beginning of vacuum physics.

For his experiments, *Knudsen* used the so-called *Gaede* pump. *Gaede*, a professor at the University of Freiburg in Germany, was the most important

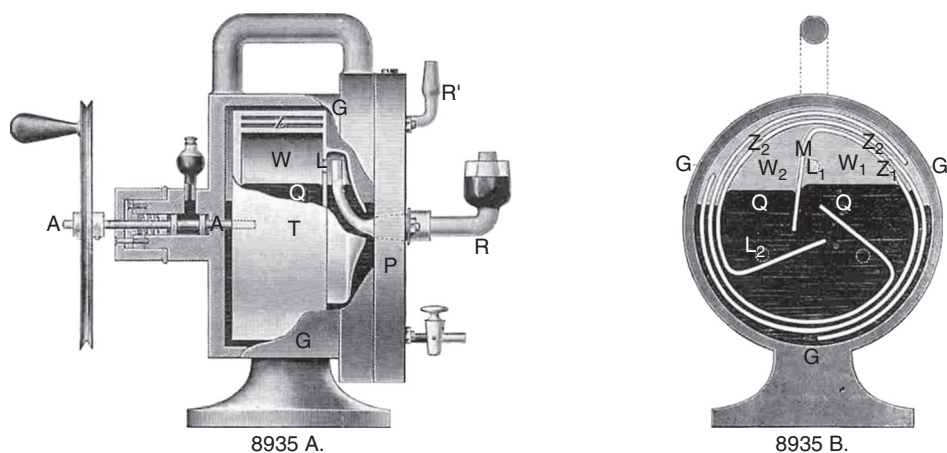

Figure 1.14 Gaede's mercury rotation pump. R indicates the position of the suction port. (With kind permission of the Gaede Foundation at Oerlikon Leybold GmbH, Cologne, Germany.)

inventor of vacuum pumps since *Guericke*. *Gaede's* pump was a rotary mercury pump (Figure 1.14), in which the *Torricellian* tube was wound up so that it allowed continuous pumping by rotary action. The pump was driven by an electromotor. Its pumping speed was 10 times faster than the *Sprengel*-type pump and produced vacua down to 1 mPa. However, it required an additional pump in series because it was able to compress the gas only up to 1/100 of atmospheric pressure.

The sliding vane rotary vacuum pump was developed between 1904 and 1910, based on an idea of aristocrat *Prince Rupprecht*, which dated back to 1657 [10]. *Gaede* optimized these pumps in 1935 by inventing the gas ballast, which allowed pumping condensable gases as well.

Gaede carefully studied *Knudsen's* work, and at a meeting of the *German Physical Society* in 1912 introduced his first molecular pump (Figure 1.15) [11]. *Gaede* used the finding that any gas molecule hitting a wall stays at its location for a while and accommodates to the wall before it leaves the same. If therefore a gas particle hits a fast moving wall, it will adopt the velocity of the wall and is transported in the direction of the motion during its sojourn time. The pumps based on this principle require very high rotor speeds and low clearances of about 20 μm between the moving wall and the fixed wall. The pump floundered on these requirements, which were too stringent for the technology available at the time. In 1958, however, *Becker* utilized the principle and invented the turbomolecular pump [12], which eased the clearance problem.

In the years 1915 and 1916, *Gaede* and *Langmuir* developed the mercury diffusion pump [13,14]. Twelve years later, the oil diffusion pump followed, which was the most widespread pump until the turbomolecular pump was developed.

In addition, vacuum measurement also developed further (Figure 1.16) using other pressure-dependent properties of gases: *Sutherland* suggested to use the

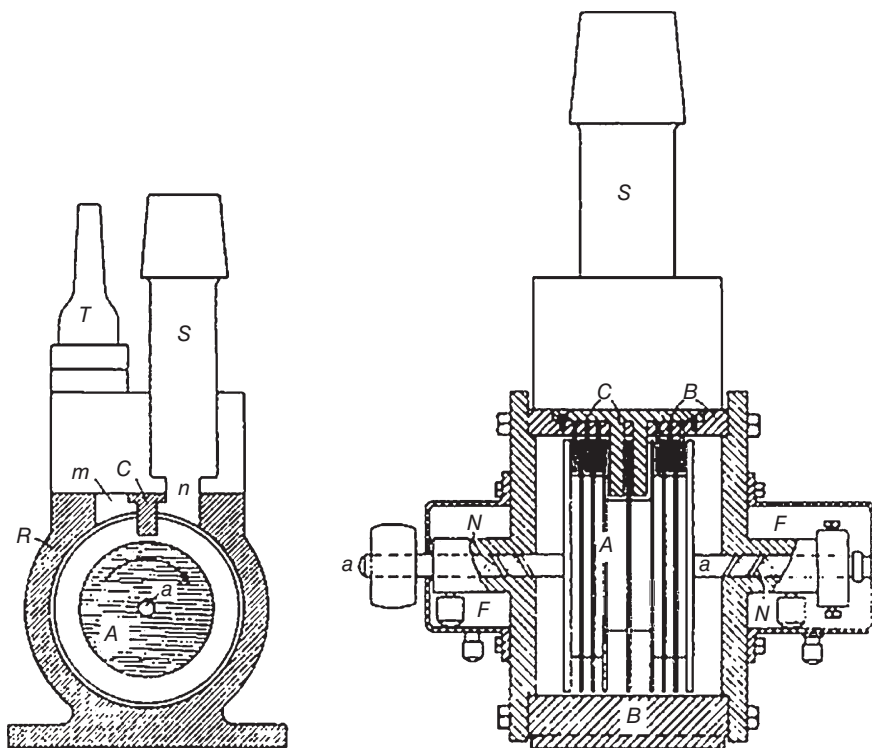

Figure 1.15 Gaede's molecular pump of 1912.

viscosity of gases in 1897. *Langmuir* put this principle into practice in 1913 using an oscillating quartz fiber. The decrement in amplitude of the oscillations gave a measure of gas pressure. In 1960, *J. W. Beams* demonstrated that the deceleration in rotational frequency of a magnetically suspended steel ball rotating at about 1 MHz under vacuum could be used as a measure of pressure. *Fremerey* optimized this device during the 1970s and 1980s. *Pirani* [15] used the pressure dependence of thermal conductivity and built the first thermal conductivity gauge in 1906. In 1909, *von Baeyer* showed that a triode vacuum tube could be used as a vacuum gauge. *Penning* invented the cold cathode gauge in 1937 in which a gas discharge is established by crossed electric and magnetic fields. During the Second World War, mass spectrometers were developed, and they became crucial parts of the weapons industry.

After World War II, it was generally believed that diffusion pumps would not be able to generate pressures below 10^{-8} Torr although the underlying effect was unknown. All manufacturers' pumping speed curves showed a value of zero at this point. The pressure was measured using triode gauges. During the *Physical Electronics Conference* in 1947, *Nottingham* suggested that the impingement of X-ray photons on the collector of the triode causing secondary electrons might

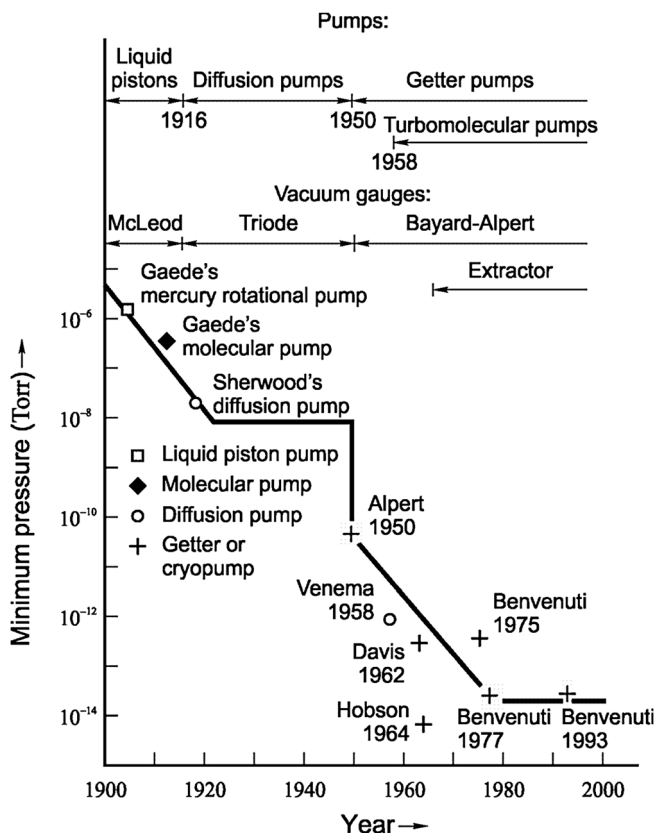

Figure 1.16 Progress in lowest pressures generated and measured in the twentieth century. (Data from Ref. [6].)

be the reason for this lower pressure limit. This was a breakthrough. A competition for a significant improvement of the ion gauge started, which *Nottingham's* own group did not win, to his regret. Instead, in 1950, *Bayard* and *Alpert* [16] succeeded with an idea as simple as ingenious (Figure 13.48).

Since all vacuum gauges except for the *McLeod* and the *Torrillian* tube had to be calibrated, and because, at the same time, vacuum industry grew to an important branch (see Chapter 2), independent metrological laboratories were set up in state-owned institutes in the late 1950s. The first were established at the *National Physical Laboratory (NPL)* in England. The *Laboratory for Vacuum Physics* (today: *Vacuum Metrology*) at the *Physikalisch-Technische Bundesanstalt*¹⁾ (*PTB*) in Germany followed in 1966, and in the 1970s the *Vacuum Laboratory* at the *National Bureau of Standards (NBS; today: NIST)* in the United States.

1) German National Metrology Institute.

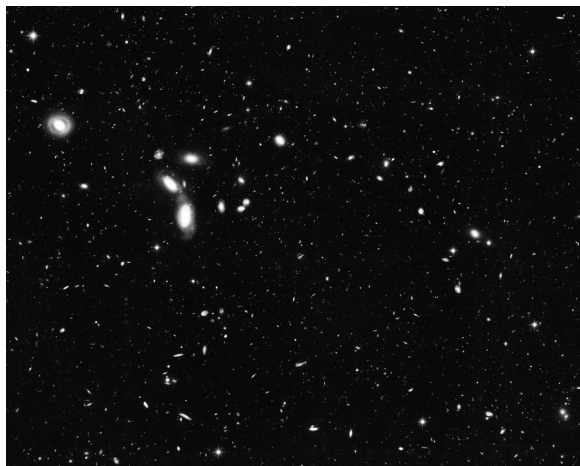

Figure 1.17 In between galaxies, there are small volumes of a few dm^3 without any massive particle (absolute or ideal vacuum). Oldest known galaxies pictured by the Hubble Space Telescope. (Courtesy of NASA.)

Coming back to the philosophical considerations at the beginning of this chapter, let us make a concluding remark on the nature of vacuum from the point of view of today's physics [17,18]: without any doubt, there are macroscopic areas, for example, small volumes between galaxies, where there is no single molecule (Figure 1.17). For such a volume, the term *absolute vacuum* was introduced. We know today, however, that even absolute vacuum is not empty (in terms of energy). Otherwise, it would not be in accordance with the laws of nature. A vacuum energy with still unknown nature, which may be related to the cosmological constant introduced by *Einstein*, permits particles to be generated spontaneously by fluctuating quantum fields for short time intervals, even in *absolute vacuum*. In this sense, there is no space in the world, which is truly empty.

References

- 1 Aristotle (1997) *Physica*, Akademie Verlag, Berlin.
- 2 Middleton, W.E.K. (1964) *The History of the Barometer*, John Hopkins University Press, Baltimore, MD.
- 3 Sparnaay, M.J. (1992) *Adventures in Vacuum*, Elsevier Science, North-Holland, p. 78.
- 4 de Guericke, O. (1672) *Experimenta Nova Magdeburgica de Vacuo Spatio*, Amstelodami.
- 5 Zur Geschichte der Vakuumtechnik, six reports in *Vak.-Tech.*, **35** (4/5), 99–157 (1986).
- 6 Redhead, P.A. (1999) The ultimate vacuum. *Vacuum*, **53**, 137–149.
- 7 McLeod, H.G. (1874) Apparatus for measurement of low pressures of gas. *Philos. Mag.*, **48**, 110 ff.; *Proc. Phys. Soc.*, **1**, 30–34 (1874).

- 8 Madey, T.E. (1984) Early applications of vacuum, from Aristotle to Langmuir. *J. Vac. Sci. Technol. A*, **2**, 100–117.
- 9 Knudsen, M. (1909) Die Gesetze der Molekularströmung und der inneren Reibungsströmung der Gase durch Röhren. *Ann. Phys. Lpz.*, **28**, 75–130.
- 10 Redhead, P.A. (2005) Vacuum and the electron tube industry. *J. Vac. Sci. Technol. A*, **23**, 1252–1259.
- 11 Gaede, W. (1912) The external friction of gases and a new principle for vacuum pumps: The molecular pump. *Z. Phys.*, **13**, 864.
- 12 Henning, J. (1991) Die Entwicklung der Turbomolekularpumpe. *Vak. Prax.*, **1**, 28–30.
- 13 Gaede, W. (1915) Die Diffusion der Gase durch Quecksilberdampf bei niedrigen Drücken und die Diffusionsluftpumpe. *Ann. Phys.*, **6**, 357–392.
- 14 Langmuir, I. (1916) *Gen. Electr. Rev.*, **19**, 1060.
- 15 Pirani, M. (1906) Selbstanzeigendes Vakuum-Meßinstrument. *Verh. Dtsch. Phys. Ges.*, **8**, 686–694.
- 16 Bayard, R.T. and Alpert, D. (1950) Extension of low pressure range of the ionization gauge. *Rev. Sci. Instrum.*, **2**, 571–572.
- 17 Genz, H. (2004) *Nichts als das Nichts — Die Physik des Vakuums*, Wiley-VCH Verlag GmbH, p. 266.
- 18 Bojowald, M. (2011) Alles aus dem Nichts. *Phys. J.*, **10** (3), 37.

Further Reading

- Auwaerter, M. (1983) Das Vakuum und Wolfgang Gaede. *Vak.-Tech.*, **32** (8), 234–246.
- Dunkel, M. (1978) Gedenken an Wolfgang Gaede. *Vak.-Tech.*, **27**, 99–101.
- Gaede, H. (1954) *Wolfgang Gaede, Der Schöpfer des Hochvakuums*, A. Braun, Karlsruhe, p. 127.
- Hablanian, M.H. (1984) Comments on the history of vacuum pumps. *J. Vac. Sci. Technol. A*, **2**, 118–125.
- Hoppe, E. (1936/1965) *Geschichte der Physik*, Vieweg, Braunschweig.
- Jahrreiß, H. (1987) Otto von Guericke (1602–1686) in memoriam. *J. Vac. Sci. Technol. A*, **5**, 2466–2471.
- Madey, T.E. (1984) *History of Vacuum Science and Technology*, AIP, New York.
- Mulder, Th. (1987) Otto von Guericke. *Vak.-Tech.*, **35** (4/5), 101–110.
- Redhead, P. (1984) The measurement of vacuum pressures. *J. Vac. Sci. Technol. A*, **2**, 132–138.
- Singleton, J.H. (1984) The development of valves, connectors, and traps for vacuum systems during the 20th century. *J. Vac. Sci. Technol. A*, **2**, 126–131.
- von Guericke, O. (1968) *Neue Magdeburger Versuche über den leeren Raum* (German by H. Schimank), VDI-Verlag, Düsseldorf, p. 291.

