

# 1 What is Chemometrics?

## Learning objectives

- To define chemometrics
- To learn how to count with bits and how to perform arithmetic or logical operations in a computer
- To understand the principal terminology for computer systems and the meaning of robotics and automation

The development of the discipline chemometrics is strongly related to the use of computers in chemistry. Some analytical groups in the 1970s were already working with statistical and mathematical methods that are ascribed nowadays to chemometric methods. Those early investigations were connected to the use of mainframe computers.

The notation *chemometrics* was introduced in 1972 by the Swede, Svante Wold, and the American, Bruce R. Kowalski. The foundation of the International Chemometrics Society in 1974 led to the first description of this discipline. In the following years, several conference series were organized, e.g., Computer Application in Analytics (COMPANA), Computer-Based Analytical Chemistry (COBAC) and Chemometrics in Analytical Chemistry (CAC). Some journals devoted special sections to papers on chemometrics. Later, novel chemometric journals were started, such as the *Journal of Chemometrics* (Wiley) and *Chemometrics and Intelligent Laboratory Systems* (Elsevier).

An actual definition of chemometrics is:

- *the chemical discipline that uses mathematical and statistical methods, (a) to design or select optimal measurement procedures and experiments, and (b) to provide maximum chemical information by analyzing chemical data.*

The discipline of chemometrics originates in chemistry. Typical applications of chemometric methods are the development of quantitative structure activity relationships or the evaluation of analytical–chemical data. The data flood generated by modern analytical instrumentation is one reason, that analytical chemists in particular develop applications of chemometric methods. Chemometric methods in *analytics* is the discipline that uses mathematical and statistical methods to obtain relevant information on material systems.

With the availability of personal computers at the beginning of the 1980s, a new age commenced for the acquisition, processing and interpretation of chemical data. In fact, today every scientist uses software, in one form or another, that is related to

mathematical methods or to processing of knowledge. As a consequence, the necessity emerges for a deeper understanding of those methods.

The education of chemists in mathematics and statistics is usually unsatisfactory. Therefore, one of the initial aims of chemometrics was to make complicated mathematical methods practicable. Meanwhile, the commercialized statistical and numerical software simplifies this process, so that all important chemometric methods can be taught in appropriate computer demonstrations.

Apart from the statistical–mathematical methods, the topics of chemometrics are also related to problems of the computer-based laboratory, to methods for handling chemical or spectroscopic databases and to methods of artificial intelligence.

In addition, chemometricians contribute to the development of all these methods. As a rule, these developments are dedicated to particular practical requirements, such as the automatic optimization of chromatographic separations or in prediction of the biological activity of a chemical compound.

## 1.1 The Computer-based Laboratory

Nowadays the computer is an indispensable tool in research and development. The computer is linked to analytical instrumentation; it serves as a tool for acquiring data, for word processing and for handling databases and quality assurance systems. In addition, the computer is the basis for modern communication techniques such as electronic mail or video conferences. In order to understand important principles of computer usage some fundamentals are considered here, i.e., coding and processing of digital information, the main components of a computer, programming languages, computer networking and automation processes.

### Analog and digital data

The use of digital data provides several advantages over the use of analog data. Digital data are less noise sensitive. The only noise arises from round-off errors due to finite representation of the digits of a number. They are less prone to, for instance, electrical interferences and they are compatible with digital computers.

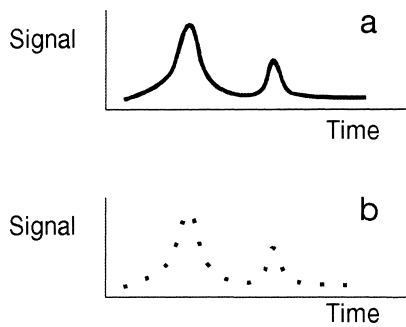

**Fig. 1-1.** Signal dependence on time of an analog (a) and a digital detector (b)

As a rule, primary data are generated as analog signals either in a discrete or a continuous mode (Fig. 1-1). For example, monitoring the intensity of optical radiation by means of a photocell provides a continuous signal. Weak radiation, however, could be monitored by detecting individual photons by a photomultiplier.

Usually, the analog signals generated are converted into digital data. This is carried out by an analog-to-digital converter as explained below.

## Binary versus decimal number system

In a digital measurement, the number of pulses occurring within a specified set of boundary conditions is counted. The easiest way to count is to have the pulses represented as binary numbers. In this way only two electronic states are required. To represent the decimal numbers from 0 to 9 one would need 10 different states. Typically, the binary numbers 0 and 1 are represented electronically by voltage signals of 0.5 V and 5 V, respectively. Binary numbers characterize coefficients of the power of 2, so that any number of the decimal system can be described.

### Example 1-1: Binary number representation

The decimal number 77 is expressed as binary number by 1001101, i.e.,

$$\begin{array}{rccccccc}
 1 & 0 & 0 & 1 & 1 & 0 & 1 \\
 1 \times 2^6 & 0 \times 2^5 & 0 \times 2^4 & 1 \times 2^3 & 1 \times 2^2 & 0 \times 2^1 & 1 \times 2^0 = \\
 64 & +0 & +0 & +8 & +4 & +0 & +1 = 77
 \end{array}$$

Table 1-1 provides further relationships between binary and decimal numbers. Every binary number is composed of individual *bits* (binary digits). The digit lying farthest to the right is termed the *least significant* digit and the one on the left is the *most significant* digit.

**Table 1-1.** Relationship between binary and decimal numbers

Binary number	Decimal number
0	0
1	1
10	2
11	3
100	4
101	5
110	6
111	7
1000	8
1001	9
1010	10
1101	13
10000	16
100000	32
1000000	64

How are calculations done using binary numbers? Arithmetic operations are similar, but simpler than those for decimal numbers. In addition, for example, four combinations are feasible:

$$\begin{array}{rcccc}
 0 & 0 & 1 & 1 \\
 +0 & +1 & +0 & +1 \\
 \hline
 0 & 1 & 1 & 10
 \end{array}$$

Note that for addition of the binary numbers 1 plus 1, a 1 is carried over to the next higher power of 2.

**Example 1-2: Calculation with binary numbers**

Consider addition of  $21 + 5$  in the case of a decimal (a) and of a binary number (b):

$$\begin{array}{rcc}
 \text{a.} & 21 & \\
 & + 5 & \\
 \hline
 & 26 & \\
 \end{array}
 \qquad
 \begin{array}{rcc}
 \text{b.} & 10101 & \\
 & + 101 & \\
 \hline
 & 11010 & \\
 \end{array}$$

Apart from arithmetic operations in the computer, logical reasoning is necessary too. This might be in the course of an algorithm or in connection with an expert system. Logical operations with binary numbers are summarized in Table 1-2.

**Table 1-2.** Truth values for logical connectives of predicates  $p$  and  $q$  based on binary numbers. 1 True, 0 false

$p$	$q$	$p$ AND $q$	$p$ OR $q$	IF $p$ THEN $q$	NOT $p$
1	1	1	1	1	0
1	0	0	1	0	–
0	1	0	1	1	1
0	0	0	0	1	–

It should be mentioned that a very compact representation of numbers is based on the *hexadecimal number system*. However, hexadecimal numbers are easily converted to binary data, so the details need not be explored here.

## Digital and analog converters

### Analog-to-digital converters (ADCs)

In order to benefit from the advantages of digital data evaluation, the analog signals are converted into digital ones. An analog signal consists of an infinitely dense sequence of signal values in a theoretically infinite small resolution. The conversion of analog into digital signals in the ADC results in a

definite reduction of information. For conversion, signal values are sampled in a predefined time interval and quantified in a  $n$ -ary raster (Fig. 1-2). The output signal is a code word consisting of  $n$  bits. Using  $n$  bits,  $2^n$  different levels can be coded, e.g., an 8-bit ADC has a resolution of  $2^8 = 256$  amplitude levels.

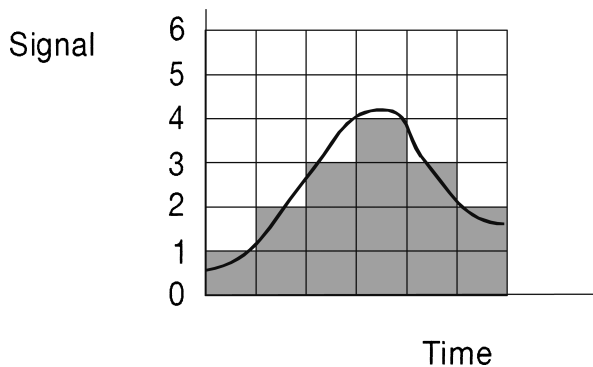

**Fig. 1-2.** Digitization of an analog signal by an analog-to-digital converter (ADC)

### Digital-to-analog converters (DACs)

Converting digital into analog information is necessary if an external device is to be controlled or if the data have to be represented by an analog output unit. The resolution of the analog signal is determined by the number of processed bits in the converter. A 10-bit DAC provides  $2^{10} = 1024$  different voltage increments. Its resolution is then  $1/1024$  or approximately 0.1%.

## Computer terminology

Representation of numbers in a computer by bits has already been considered. The combination of 8 bits is called a *byte*. A series of bytes arranged in sequence to represent a piece of data is termed a *word*. Typical word sizes are 8, 16, 32 or 64 bits, or 1, 2, 4, and 8 bytes.

Words are processed in *registers*. A sequence of operations in a register enables *algorithms* to be performed. One or several algorithms make up a *computer program*.

The physical components of a computer form the *hardware*. Hardware includes the disk and hard drives, clocks, memory units and registers for arithmetic and logical operations. Programs and instructions for the computer, including the tapes and disks for their storage, represent the *software*.

## Components of computers

### Central processing units and buses

A bus consists of a set of parallel conductors that forms a main transition path in a computer.

The heart of a computer is the central processing unit (CPU). In a microprocessor or minicomputer, this unit consists of a highly integrated chip.

The different components of a computer, its memory and the peripheral devices, such as printers or scanners, are joined by buses. To guarantee rapid communication among the various parts of a computer, information is exchanged on the basis of a definitive word size, e.g., 16 bits, simultaneously over parallel lines of the bus. A data bus serves the exchange of data into and out of the CPU. The origin and the destination of the data in the bus are specified by the address bus. For example, an address bus with 16 lines can address  $2^{16} = 65536$  different registers or other locations in the computer or in its memory. Control and status informations to and from the CPU are administrated in the control bus. The peripheral devices are controlled by an external bus system, e.g., an RS-232 interface for serial data transfer or the IEEE-488 interface for parallel transfer of data.

### Memory

The microcomputer or microprocessor contains typically two kinds of memory: *random access memory* (RAM) and *read-only memory* (ROM). The term RAM is somewhat misleading and historically reasoned, since random access is feasible for RAM and ROM alike. The RAM can be used to read and write information. In contrast information in a ROM is written once, so that it can be read, but not reprogrammed. ROMs are needed in microcomputers or pocket calculators in order to perform fixed programs, e.g., for calculation of logarithms or standard deviations.

Larger programs and data collections are stored in *bulk storage devices*. In the beginning of the computer age, magnetic tapes were the standard here. Nowadays tapes are still used for archiving large data amounts. Routinely, 3.5" disks (formerly 5¼") are used providing a storage capacity of 1.44 MB. In addition, every computer is equipped with a hard disk of at least 20 MB, and up to several GB. The access time to retrieve the stored information is in the order of a few milliseconds.

At present, the availability of optical storage media is increasing. CD-ROM drives serve for reading large programs or databases. An optical hard disk can be used either to read or write information. Although optically based bulk storage devices have slower access times than magnetic bulk storage media, their storage capacity is larger.

### Input/output-systems

Communication with the computer is carried out by input-output (I/O) operations. Typical input devices are the keyboard, magnetic tapes and disks or the signals of an analytical instru-

ment. Output devices are screens, printers and plotters, as well as tapes and disks. To convert analog information into digital or vice versa, the above-mentioned ADCs or DACs are used.

## Programs

Programming a computer at 0 and 1 states or bits is possible using *machine code*. Since this kind of programming is rather time consuming, higher level languages have been developed where whole groups of bit-operations are assembled. However, these so-called *assembler languages* are still difficult to handle. Therefore, high-level algorithmic languages, such as FORTRAN, BASIC, PASCAL or C, are more common in analytical chemistry. With high-level languages, the instructions for performing an algorithm can easily be formulated in a computer program. Thereafter, these instructions are translated into machine code by means of a *compiler*.

For logical programming, additional high-level languages exist, e.g., LISP (List Processing language) or PROLOG (Programming in Logic). Further developments are found in so-called *Shells*, which can be used directly for building expert systems.

## Networking

A very effective communication between computers, analytical instruments, and databases is based on networks. There are local nets, e.g., within an industrial laboratory as well as national or worldwide networks. Local area networks (LANs) are used

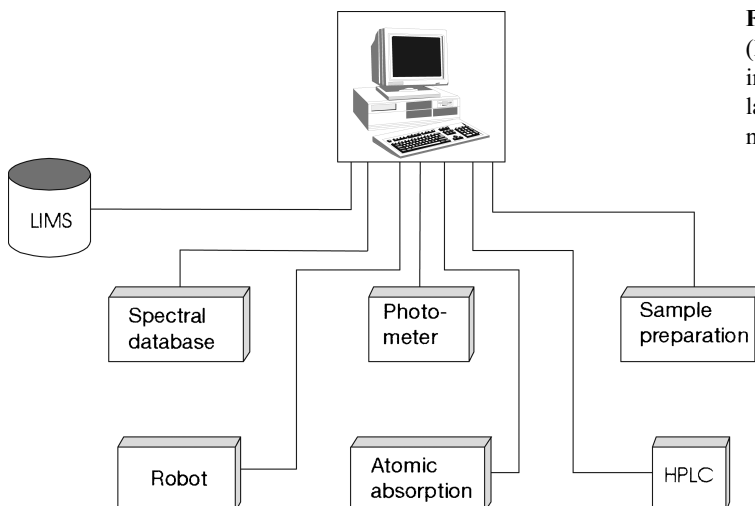

**Fig. 1-3.** Local area network (LAN) to connect analytical instruments, a robot and a laboratory-and-information-management system (LIMS)

to transfer information about analysis samples, measurements, research projects, or in-house databases. A typical LAN is demonstrated in Fig. 1-3. It contains a laboratory-and-information management system (LIMS), where all information about the sample or the progresses in a project can be stored and further processed (cf. Section 7.1).

Worldwide networking is feasible, e.g., via Internet or CompuServe. These nets are used to exchange electronic mails (e-mail) or data with universities, research institutions, or industry.

## Robotics and automation

Apart from acquiring and processing analytical data, the computer can also be used to control or supervise automatic procedures. To automate manual procedures, a *robot* is applied. A robot is a reprogrammable device that can perform a task more cheaply and effectively than a person.

Typical geometric shapes of a robot arm are sketched in Fig. 1-4. The anthropomorphic geometry (Fig. 1-4A) is derived from the human torso, i.e., there is a waist, shoulder, elbow, and wrist. Although this type of robot is mainly found in the automobile industry, it can also be used for manipulation of liquid or solid samples.

**Fig. 1-4.** Anthropomorphic (A) and cylindrical (B) geometry of robot arms

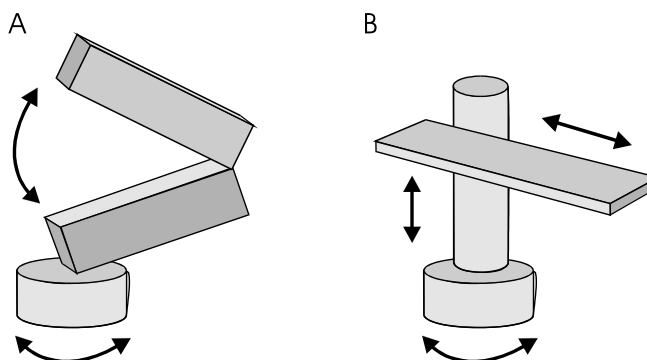

In the chemical laboratory, the cylindrical geometry dominates (Fig. 1-4B). The revolving robot arm can be moved in horizontal and vertical directions. Typical operations of a robot are:

- *Manipulation* of test tubes or glass ware around the robotic work area.
- *Weighing*, for determination of a sample amount or for checking unit operations, e.g., addition of a solvent.
- *Liquid handling*, in order to dilute or add reagent solutions.
- *Conditioning* of a sample by heating or cooling.
- *Separations* based on filtrations or extractions.



- *Measurements* by analytical procedures, such as spectrophotometry or chromatography.
- *Control and supervision* of the different analytical steps.

*Programming* of a robot is based on software dedicated to the actual manufacture. The software consists of elements to control the peripheral devices (robot arm, balance, pumps), to switch the devices on and off, and to provide instructions on the basis of logical structures, e.g., IF–THEN rules.

Alternatives for automation in a laboratory are *discrete analyzers* and *flowing systems*. By means of discrete analyzers, unit operations such as dilution, extraction or dialyses can be automated. Continuous flow analyzers or flow injection analyses serve similar objectives for automation, e.g., for the determination of clinical parameters in blood serum.

The transfer of manual operations to a robot or an automated system provides the following advantages:

- high productivity and/or minimization of costs;
- improved precision and trueness of results;
- increased assurance for performing laboratory operations;
- easier validation of the different steps of an analytical procedure.

The increasing degree of automation in the laboratory leads to more and more measurements that are available online in the computer and have to be further processed by chemometric data evaluation methods.

## 1.2 Statistics and Data Interpretation

Table 1-3 provides an overview of chemometric methods. The main emphasis is on statistical–mathematical methods. Random data are characterized and tested by the descriptive and inference methods of statistics, respectively. Their importance increases in connection with the aims of quality control and quality assurance. Signal processing is carried out by means of algorithms for smoothing, filtering, derivation and integration. Transformation methods such as the Fourier or Hadamard transformations also belong in this area.

Efficient experimentation is based on the methods of experimental design and its quantitative evaluation. The latter can be performed by means of mathematical models or graphical representations. Alternatively, sequential methods are applied, such as the simplex method, instead of these simultaneous methods of

**Table 1-3.** Chemometric methods for data evaluation and interpretation

Descriptive and inference statistics
Signal processing
Experimental design
Modeling
Optimization
Pattern recognition
Classification
Artificial intelligence methods
Image processing
Information and system theory

experimental optimization. There, the optimum conditions are found by systematic search for the objective criterion, e.g., the maximum yield of a chemical reaction, in the space of all experimental variables.

To find patterns in data and to assign samples, materials or in general, objects, to those patterns, multivariate methods of data analysis are applied. Recognition of patterns, classes or clusters is feasible with projection methods, such as principle component analysis or factor analysis, or with cluster analysis. To construct class models for classification of unknown objects we will introduce discriminant analyses.

To characterize the information content of analytical procedures, information theory is used in chemometrics.

### 1.3 Computer-based Information Systems/ Artificial Intelligence

A further subject of chemometrics is the computer-based processing of chemical structures and spectra.

There, it might be necessary to extract a complete or partial structure from a collection of molecular structures, or to compare an unknown spectrum with the spectra of a spectral library.

For both kinds of queries, methods for representation and manipulation of structures and spectra in databases are needed. In addition, problems of data exchange formats, e.g., between a measured spectrum and a spectrum of a database, are to be decided.

If no comparable spectrum is found in a spectral library, then methods for spectra interpretation become necessary. For interpretation of atomic and molecular spectra, in principle, all the

statistical methods for pattern recognition are appropriate (cf. Section 1.2). In addition, *methods of artificial intelligence* are used. They include methods of logical reasoning and tools for developing expert systems. Apart from the methods of classical logic in this context also methods of approximate reasoning and of *fuzzy logic* can be exploited. These interpretation systems constitute methods of *knowledge processing* in contrast to data processing based on mathematical–statistical methods.

Knowledge acquisition is mainly based on expert knowledge, e. g., the infrared spectroscopist is asked to contribute his knowledge in the development of an interpretation system for infrared spectra. Additionally, methods are required for automatic knowledge acquisition in form of *machine learning*.

The methods of artificial intelligence and machine learning are not restricted to the interpretation of spectra. They also can be used to develop expert systems, e.g., for the analysis of drugs or the synthesis of an organic compound.

Novel methods are based on biological analogs, such as neural networks and evolutionary strategies, e. g., genetic algorithms. Future areas of research for chemometricians will include the investigation of *fractal structures* in chemistry and of models based on the theory of *chaos*.

Methods based on fuzzy theory, neural nets and evolutionary strategies are denoted *soft computing*.

## 1.4 General Reading

Sharaf, M. A., Illman, D. L., Kowalski, B. R., *Chemometrics, Chemical Analysis Series Vol. 82*: Wiley, New York, 1986.

Massart, D. L., Vandeginste, B. G. M., Deming, S. N., Michotte, Y., Kaufmann, L., *Chemometrics—a Textbook*: Elsevier, Amsterdam, 1988.

### Questions and Problems

1. Calculate the resolution for 10-, 16- and 20-bit analog-to-digital converters.
2. How many bits are stored in an 8-byte word?
3. What is the difference between procedural and logical programming languages?
4. Discuss typical operations of an analytical robot.

