

1

Fundamental Concepts

Nuclear and radiochemistry cover a wide spectrum of areas such as (i) studies of the chemical and physical properties of the heaviest human-made elements; (ii) studies of nuclear structure, nuclear reactions, and radioactive *decay*, (iii) studies of nuclear processes in the Universe, such as geochronology and cosmochemistry; and (iv) applications of radioactivity in a vast variety of fields such as *radioanalysis*, chemistry, life sciences, and industrial applications, and in the geo- and biosphere. Nuclear chemistry has ties to all traditional areas of chemistry. Nuclear chemists are involved in the preparation of radiopharmaceuticals for use in medicine. Radiometric techniques play an important role in analytical chemistry and are often used as references validating other analytical techniques. The study of the actinide and transactinide elements has traditionally involved nuclear chemists studying the limits of nuclear stability and the periodicity of the periodic table of the elements. The physical concepts at the heart of nuclear chemistry have their roots in nuclear physics. Thus, nuclear physics and nuclear chemistry overlap and are cooperatively called nuclear science. However, there are distinctions between these related fields. Besides the close ties to chemistry mentioned earlier, nuclear chemists are studying nuclear problems in different ways than nuclear physicists. Nuclear physics tends to look into the fundamental interactions between subatomic particles and fundamental symmetries. Nuclear chemists have focused on more complex phenomena where statistical properties are important. Nuclear chemists are more involved in applications of nuclear phenomena. For example, the nuclear fuel cycle or the migration of *radionuclides* in the environment is so inherently chemical that they involve nuclear chemists almost exclusively. The other term, radiochemistry, refers to the chemical applications of radioactivity and of related phenomena. Radiochemists are nuclear chemists but not all nuclear chemists are radiochemists. There are many nuclear chemists who use purely instrumental, physical techniques for their research and thus their work is not radiochemistry.

1.1 The Atom

The atom is the smallest unit a chemical element can be divided into without losing its chemical properties. The radii of atoms are on the order of 10^{-10} m (Å). The

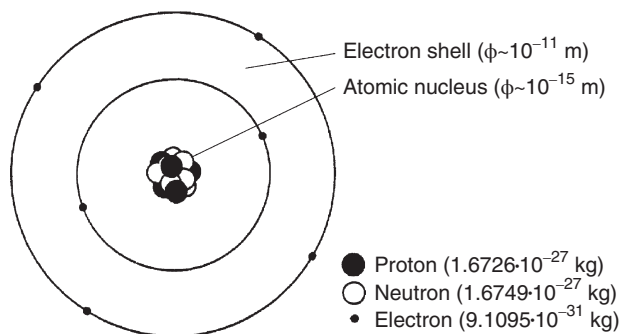

Figure 1.1 Schematic representation of the relative sizes of the atom and the nucleus.

atomic nucleus, see Figure 1.1, is a very small object with a radius on the order of $1-10 \cdot 10^{-15}$ m (femtometer, fm, called fermi) in the center of the atom and contains almost the entire mass of the atom. It contains Z protons, where Z is the atomic number of the element. Being the number of protons, Z is thus the number of positive charges in the nucleus. The nucleus also contains N neutrons, where N is the neutron number. Neutrons are uncharged particles with masses almost identical to the proton mass. Electrons surround the nucleus. Electrons are small negatively charged particles with a mass of $1/1836$ of the proton mass. The electrons are bound electrostatically to the positively charged nucleus. In a neutral atom, the number of electrons equals the number of protons in the nucleus. The chemistry of the element is controlled by Z . From quantum mechanics, we know that only certain discrete energies and angular momenta of the electrons are allowed. These quantized states are schematically depicted in Figure 1.1. Later, in Chapter 5, we will see also that *nucleons* occupy orbits with discrete energies and angular momenta. However, the sizes and energies of atomic and nuclear processes are very different, allowing us to consider them separately.

1.2 Atomic Processes

In the inelastic collision of two atoms, we can anticipate (i) excitation of one or both atoms involving a change in electron configuration or (ii) ionization of one or both atoms, that is, removal of one or more electrons from the atom to form a positively charged ion. For this process to occur, an atomic electron must receive an energy exceeding its binding energy. This energy far exceeds the kinetic energies of gaseous atoms at room temperature. Thus, the atoms must have high kinetic energies as a result of nuclear decay or acceleration to eject electrons from other atoms in atomic collisions. When an electron in an outer atomic electron shell drops down to fill a vacancy in an inner electron shell, electromagnetic radiation called X-rays is emitted. In Figure 1.2, an L-shell electron is shown filling a K-shell vacancy. In the transition, a characteristic K X-ray is emitted. The energy of the X-rays is equal to the difference in the binding energies of the electrons in the two shells, which

Figure 1.2 Scheme showing X-ray emission when a vacancy in an inner electron shell caused by nuclear decay is filled. An L-shell electron is shown filling a K-shell vacancy associated with K X-ray emission.

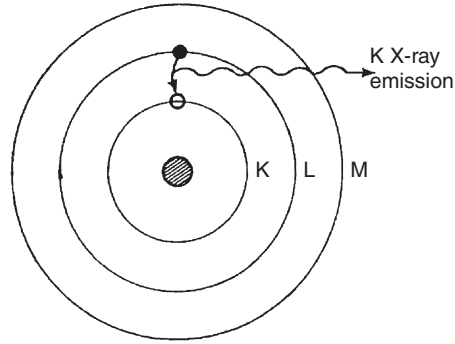

depends on the atomic number of the element. Specifically, X-rays due to transitions from the L shell to the K shell are called K_{α} X-rays, while X-rays due to transitions from the M to K shells are termed K_{β} X-rays. Refining further, $K_{\alpha 1}$ and $K_{\alpha 2}$ designate transitions from different subshells of the L shell, that is, $2p_{3/2}$ (L_{III}) and $2p_{1/2}$ (L_{II}). X-rays for transitions from M to L are L_{α} X-rays. For each transition, the change in orbital angular momentum $\Delta \ell$ and total angular momentum Δj must be $\Delta \ell = \pm 1$ and $\Delta j = 0, \pm 1$.

For a hydrogen-like atom, the Bohr model predicts that the transition energy ΔE is

$$\Delta E = E_i - E_f = R_{\infty} hc Z^2 \left(\frac{1}{n_i^2} - \frac{1}{n_f^2} \right) \quad (1.1)$$

where R_{∞} is the Rydberg constant, h the Planck constant, c the speed of light, and n the principal quantum number of the electron. The X-ray energy $E_x = -\Delta E$, after inserting the physical constants, is

$$E_x = 13.6 Z^2 \left(\frac{1}{n_f^2} - \frac{1}{n_i^2} \right) \text{ eV} \quad (1.2)$$

For K_{α} X-rays from hydrogen-like atoms

$$E_x = 13.6 Z^2 \left(\frac{1}{1^2} - \frac{1}{2^2} \right) \text{ eV} \quad (1.3)$$

and for L_{α} transitions

$$E_x = 13.6 Z^2 \left(\frac{1}{2^2} - \frac{1}{3^2} \right) \text{ eV} \quad (1.4)$$

In a realistic atom, Z must be replaced by $Z_{\text{effective}}$ to take care of the screening of the nuclear charge by other electrons. Henry Moseley showed the frequencies, ν , of the K_{α} X-rays scale as

$$\nu^{1/2} = \text{const}(Z - 1) \quad (1.5)$$

and those of the L_{α} X-rays scale as

$$\nu^{1/2} = \text{const}(Z - 7.4) \quad (1.6)$$

Thus, Moseley showed that the X-ray energies, $h\nu$, depend on the square of an altered, effective atomic number due to screening. The relative intensities of different X-rays depend on the chemical state of the atom, its oxidation state, complexation with ligands, and generally on local electron density. The relative intensities are, therefore, useful in chemical speciation studies. As will be discussed in Chapter 6, radioactive decays can be accompanied by X-ray production and the latter may be used to identify the decaying nucleus.

1.3 Discovery of the Atomic Nucleus

Before the discovery of radioactivity, elements were considered as unchangeable substances. In 1897, J.J. Thomson discovered the electron and concluded that the atom must have a structure. As the mass of the electron is roughly 1/2000 of the mass of hydrogen, he concluded that most of the mass of the atom must be contained in the positively charged constituents. It was assumed that negative and positive charges are evenly distributed over the atomic volume.

In 1911, Ernest Rutherford studied the scattering of α particles in thin metal foils. He found that backscattering to $\theta > 90^\circ$ was more frequent than expected for multiple scattering from homogeneously charged atoms. This led Rutherford to postulate the existence of an atomic nucleus having mass and positive charges concentrated in a very small volume. The nucleus was supposed to be surrounded by electrons at the atomic diameter and the electrons do not contribute to the α -particle scattering. He postulated the following ansatz: the nuclear charge is Ze ; that of the α particle is $Z_\alpha = 2e$. The scattering force is the Coulomb force. The nucleus is at rest in the collision, and the path of an α particle in the field of the nucleus is a hyperbola with the nucleus at the external focus. From these simplifying geometric properties and from the conservation of momentum and energy, Rutherford derived his famous scattering formula which relates the number $n(\theta)$ of α particles scattered into a unit area S at a distance r from the target foil F, see Figure 1.3, to the scattering angle θ

$$n(\theta) = n_0 \frac{Nt}{16r^2} \left(\frac{ZeZ_\alpha e}{\frac{1}{2}M_\alpha v_\alpha^2} \right)^2 \frac{1}{\sin^4(\theta/2)} \quad (1.7)$$

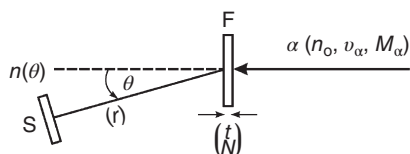

Figure 1.3 Schematic representation of the Rutherford scattering experiment. A collimated beam of α particles (n_0 number of ingoing α particles with velocity v_α and rest mass M_α) hits a gold foil F (thickness t , N number of target nuclei per cubic centimeter) and is scattered to the polar angle θ under which a scintillator S at distance r from the target detects $n(\theta)$ scattered particles.

with n_0 being the number of incident α particles, t the thickness of the target foil, N the number of target nuclei per unit volume, and M_α and v_α the mass and initial velocity of the α particle.

Precision measurements by Hans Geiger and Ernest Marsden soon verified that, for sufficiently heavy scatterers, the number of scattered particles detected per unit area was indeed inversely proportional to the square of the α -particle energy and to the fourth power of the sine of half the scattering angle. In principle for all, but notably only for light target nuclei, Eq. (1.7) must be modified because the target nucleus is not at rest. This can be accommodated by inserting the center of mass energy instead of the laboratory energy and by using the reduced mass instead of the rest mass. Figure 1.4 shows the apparatus used by Geiger and Marsden. It resembled an exsiccator that could be evacuated. The upper part contained the α -particle source (in German *Emanationsröhrchen*, R) in a lead brick. The collimated beam of α particles passed a gold foil F. The α particles that, after scattering in F, interacted with the scintillator S were observed through the microscope M. The microscope together with the scintillator could be moved to different scattering angles θ by turning the flange (*Schliff*, Sch). Figure 1.5 shows the results obtained by Geiger and Marsden. They agree in an impressive way over 5 orders of magnitude with the theoretical dependence $(1/\sin^4(\theta/2))$ for pure Coulomb scattering. This way, it was possible to study systematically the magnitude of the nuclear charge in the atoms of given elements through scattering experiments since the scattered intensity depends on the square of the nuclear charge. It was by the method of α -particle scattering

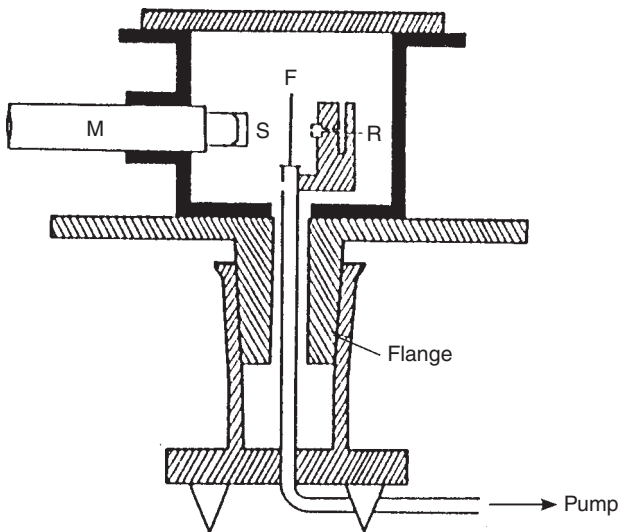

Figure 1.4 Experimental setup by Geiger and Marsden for the observation of Rutherford scattering of α particles in a gold foil F. The radioactive source R is contained in a lead housing. The scattered α particles are interacting with the scintillator S that is observed by a microscope M. The microscope together with the scintillator could be turned to variable scattering angles θ by turning the flange. Source: Geiger and Marsden (1913), figure 1 (p. 607)/Taylor & Francis.

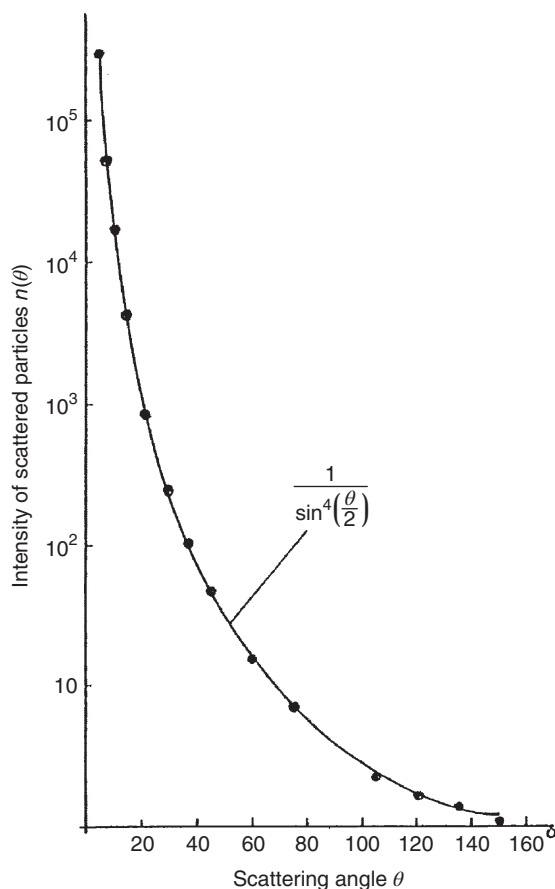

Figure 1.5 Intensity of scattered α particles measured by Geiger and Marsden as a function of scattering angle θ . The solid line represents a $1/\sin^4(\theta/2)$ function representing the theoretical dependence for pure Coulomb scattering.

that nuclear charges were determined and this led to the suggestion that the atomic number Z of an element was identical to the nuclear charge. Further understanding of atomic structure developed rapidly through the study of X-rays and optical spectra, culminating in Niels Bohr's theory of 1913 and Erwin Schrödinger's and Werner Heisenberg's quantum mechanical description of the atom in 1926.

1.4 Nuclear Decay Types

Radioactive decay involves the spontaneous emission of radiation by an unstable nucleus. While this subject will be discussed in detail in Chapter 6, we present here a general introduction. In Table 1.1, we summarize the characteristics of the various decay types. Three basic decay modes were discovered by Rutherford starting in 1899: α decay, β decay, and γ radiation. He found that α particles are completely absorbed in thin metal foils, for example, $15 \mu\text{m}$ of Al. β particles were found to be largely absorbed only in Al a 100 times thicker. An absorption equation $I = I_0 e^{-\mu d}$ was found where μ is a mass absorption coefficient (cm^{-1}) depending on Z of the

Table 1.1 Characteristics of radioactive decay modes.

Decay mode	Symbol	Emitted particle	Decay process and example (in short form)
α decay	α	Helium	${}^4_2\text{He}^{2+}$ $AZ \rightarrow A-4(Z-2) + {}^4_2\text{He}^{2+}$
β decay	β^-	Electron and antineutrino	${}^0_{-1}\text{e}^-$ ${}^0_0\text{n} \rightarrow {}^1_1\text{p} + {}^0_1\text{e}^- + {}^0_0\bar{\nu}_e$ (in the nucleus) $AZ \rightarrow A(Z+1)$ ${}^{14}\text{C}(\beta^-){}^{14}\text{N}$
	β^+	Positron and neutrino	${}^0_1\text{e}^+$ ${}^1_1\text{p} \rightarrow {}^1_0\text{n} + {}^0_1\text{e}^+ + {}^0_0\nu_e$ (in the nucleus) $AZ \rightarrow A(Z-1)$ ${}^{11}\text{C}(\beta^+){}^{11}\text{B}$
Electron capture (EC)	ϵ	Neutrino and X-ray of the daughter nuclide	ν_e ${}^1_1\text{p}(\text{nucleus}) + {}^0_{-1}\text{e}^-(\text{electron shell}) \rightarrow {}^1_0\text{n} + {}^0_0\nu_e$ $AZ \rightarrow A(Z-1)$ ${}^{37}\text{Ar}(\epsilon){}^{37}\text{Cl}$
γ transition	γ	Photon	$(h\nu)$ Electromagnetic decay of an excited nucleus
Internal conversion (IC)	e^-	Conversion electron and accompanying processes	Transfer of excitation energy to an electron in the shell ${}^{58\text{m}}\text{Co}(\text{e}^-){}^{58}\text{Co}$
Spontaneous fission	sf	Fission fragments	$AZ \rightarrow A'Z' + A-A'(Z-Z')$ ${}^{254}\text{Cf}(\text{sf})\dots$
Proton decay	p	Proton	${}^1_1\text{p}$ $AZ \rightarrow A-1(Z-1) + {}^1_1\text{p}$ ${}^{147}\text{Tm}(\text{p}){}^{146}\text{Er}$
Cluster decay	C	Cluster	${}^{223}\text{Ra} \rightarrow {}^{14}\text{C} + {}^{209}\text{Pb}$

absorber and d was the thickness in centimeter. γ radiation was found to be almost not absorbed (in aluminum) and a mass absorption coefficient depending on Z^5 was associated with it. Therefore, today, thick bricks of lead are commonly used in radiochemical laboratories for shielding purposes. Recognition of the character of the α and β rays as high-speed charged particles came largely from magnetic and electrostatic deflection experiments in which β particles were seen to be electrons. From the deflection of α particles, the ratio of charge to mass was found to be half that of the hydrogen ion. The suggestion that α particles were ${}^4\text{He}^{2+}$ ions was immediately made. This was proven in 1903 by William Ramsay in an experiment in which α rays were allowed to pass through a very thin glass wall into an evacuated glass vessel. Within a few days, sufficient helium gas was accumulated in the glass vessel and was detected spectroscopically. γ radiation was found not to be deflected in the magnetic field and was recognized to be electromagnetic radiation. The difference to the atomic X-ray radiation, however, was not clear at that time.

Nuclear β decay occurs in three ways: β^- , β^+ , and electron capture (EC). In these decays, a nuclear neutron or proton changes into a nuclear proton or neutron,

respectively, with the simultaneous emission of an antineutrino or an electron neutrino and an electron or positron. In EC, an orbital electron is captured by the nucleus changing a proton into a neutron with the emission of a monoenergetic neutrino. Due to the creation of a hole in the electron shell, the subsequent emission of X-rays or Auger electrons occurs. The *mass number* A remains constant in these decays while the atomic number Z is increased by 1 unit in β^- decay and decreased by 1 unit in β^+ decay and EC. In β^- and β^+ decay, the decay energy is shared between the emitted β particle, the (anti)neutrino, and the recoiling daughter nucleus.

Nuclear electromagnetic decay occurs in two ways: γ emission and internal conversion (IC). A nucleus in an excited state decays by the emission of a high-energy photon or the same excited nucleus transfers its decay energy radiation-less to an orbital electron that is ejected from the atom. As in EC, the creation of a hole in the electron shell causes accompanying processes to occur, such as X-ray emission. There is no change in the number of the nucleons.

In 1940, K.A. Petrzhak and G.N. Flerov discovered spontaneous fission of ^{238}U when they spread out a thin layer of uranium in a large area ionization chamber operated in a Moscow underground train station (to shield against cosmic radiation), observing large ionization bursts much larger than the pulse heights of the abundantly emitted α particles. A spontaneous fission half-life of 10^{16} years was estimated. It was concluded that the gain in binding energy delivers the decay energy when a nucleus with A nucleons splits into two fission fragments of roughly $A/2$.

In 1981, the emission of monoenergetic protons was discovered by S. Hofmann et al. at the GSI Helmholtz Center for Heavy Ion Research, Darmstadt. This proton radioactivity is now a widespread decay mode of very neutron-deficient nuclei. In 1984, H.J. Rose and G.A. Jones discovered cluster radioactivity in the decay of ^{223}Ra , which emits, with a probability of $8.5 \cdot 10^{-10}$ relative to the α particle emission, ^{14}C clusters and decays into ^{209}Pb . Heavier clusters are emitted from heavier nuclei with decreasing probabilities: for example, ^{238}Pu decays by emission of ^{28}Mg into ^{210}Pb and by emission of ^{32}Si into ^{206}Hg with probabilities of $5.6 \cdot 10^{-17}$ and $1.4 \cdot 10^{-16}$ relative to the α -particle emission.

In 1903 Rutherford was the first scientist to observe the laws of radioactive decay and growth of a radioactive gas emanating from a thorium salt, radon. He used an electroscopes, see Figure 1.6, for these radioactivity measurements. In the electroscopes, the pointer G, a gold wire, deflected from the central metal bar when the upper part of the condenser was electrically charged relative to the housing. The condenser is discharged by ionizing radiation leading to a decrease in the deflection of the pointer G with a constant speed being a measure of the “saturation current,” the *activity*. Figure 1.7 shows schematically the two experiments that Rutherford conducted with 55 seconds ^{220}Rn . In version (a), the gas inlet and outlet valves in the lower part of the housing are closed. The ^{228}Th source is placed inside the electroscopes and is covered so that only the ^{220}Rn emanating from the thorium salt can diffuse into the free volume and discharge the condenser, giving rise to a constant activity; see the activity vs. time diagram to the right. At a given time indicated by the arrow, the gas inlet and outlet valves are opened and the lower part of the electroscopes is flushed with gas, thus removing the ^{220}Rn from the electroscopes and

Figure 1.6 Electroscope for the measurement of radioactivity. The gold wire G strives against the strut when the upper plate of the condenser is electrically charged relative to the housing. S is an insulator. For charging the condenser, a high voltage is applied to position A. Ionizing radiation is discharging the condenser, visible by a decrease in the deflection of the gold wire from the central metal bar with a constant velocity.

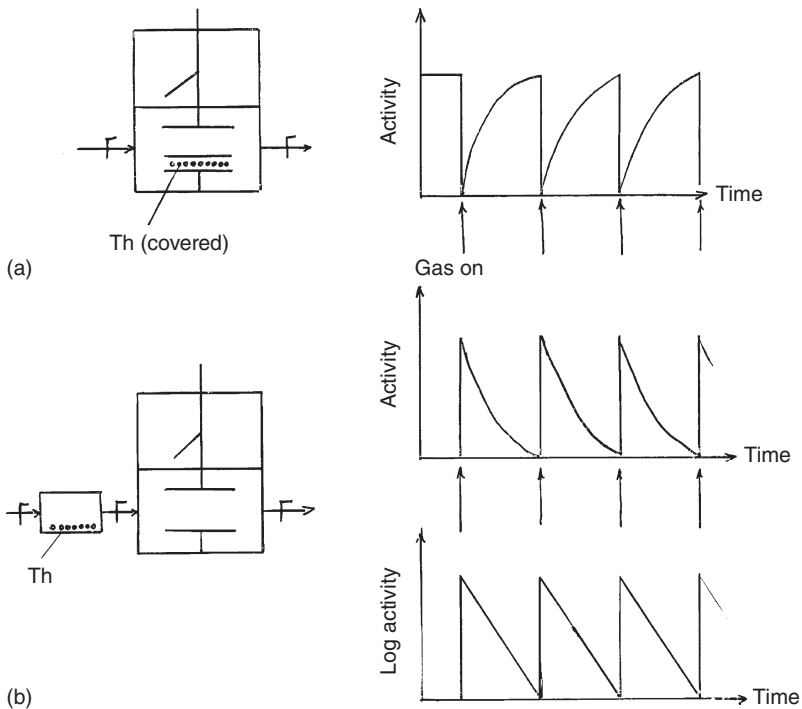
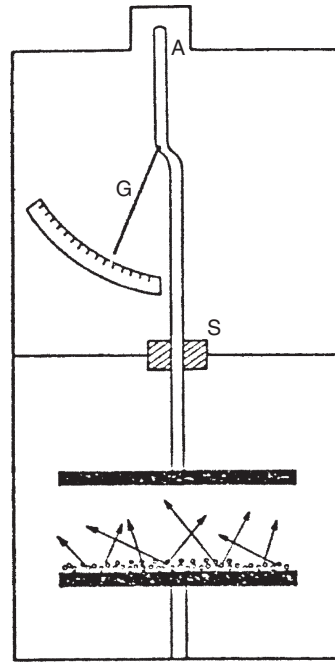

Figure 1.7 Rutherford observed the growth (a) and decay (b) of a radioactive gas (55 seconds ^{220}Rn) emanating from a Th source (1.9 years ^{228}Th).

causing the activity to fall to zero. Upon closing the valves, new ^{220}Rn grows from the ^{228}Th such that the activity discharging the condenser increases until the old saturation activity is reached. This can be repeated over and over again, showing each time the same characteristic time dependence. In version (b), the ^{228}Th source is placed in a box outside the electroscope and the activity is zero. On opening the valves and flushing ^{220}Rn into the electroscope with a carrier gas and closing the valves shortly thereafter, the ^{220}Rn decays with a characteristic time dependence. This can also be repeated over and over again. In the lower right part of Figure 1.7, the logarithm of the activity is plotted vs. time giving a linear decrease with time

$$\ln A(t) = \ln A_0 - \lambda t \quad (1.8)$$

where $A(t)$ is the activity A vs. time t , A_0 is the activity at time zero, and λ is the *decay constant*. In this way, the radioactive decay law

$$A(t) = A_0 \cdot e^{-\lambda t} \quad (1.9)$$

was discovered. The unit of activity is $1 \text{ decay s}^{-1} = 1 \text{ Becquerel} = 1 \text{ Bq}$. The decay constant, λ , is characteristic for each nuclide and is related to the nuclear half-life, $t_{1/2}$, by

$$\lambda = \ln 2 / t_{1/2} \quad (1.10)$$

The activity is equal to the number of nuclei present, N , multiplied by the decay constant λ , that is, $A = \lambda N$. Therefore, the number of radioactive nuclei present will also decrease exponentially as

$$N(t) = N_0 e^{-\lambda t} \quad (1.11)$$

1.5 Some Physical Concepts Needed in Nuclear Chemistry

Some important physical concepts need to be reviewed here because we will make use of them in later discussions.

1.5.1 Fundamental Forces

All interactions in nature are the result of four fundamental forces, see Table 1.2. The weakest force is gravity. It is most significant when the interacting objects are massive, such as stars. The next stronger force is the weak interaction which acts in nuclear β decay. The electromagnetic force is next in strength, while the strong interaction is more than a hundred times stronger than the electromagnetic force. The ranges associated with the four forces are given in Table 1.2 along with their strengths relative to the strong force and with the respective force *carriers* or exchange particles. Among these, gravitons have not yet been observed but are believed to be responsible for gravity, which is not a part of the Standard Model of particle physics, see Section 1.5.6. In Chapter 6, we will see that Glashow, Salam,

Table 1.2 Fundamental forces in nature.

Force	Range (m)	Relative strength	Force carrier
Gravitational	∞	10^{-38}	Graviton?
Weak interaction	10^{-18}	10^{-5}	W^\pm, Z^0
Electromagnetic	∞	$\alpha = 1/137$	Photon
Strong interaction	10^{-15}	1	Gluon

and Weinberg introduced a unified theoretical treatment of electromagnetic and weak interactions, the electroweak interaction, in which the photon and the massive vector bosons W^\pm and Z^0 emerge from one theory. We note in passing that the free neutron undergoes interactions with all four forces at the same time, see Chapter 8.

1.5.2 Elements from Classical Mechanics

A force is a vector that describes the rate of change of a momentum with time

$$\mathbf{F} = \frac{d\mathbf{p}}{dt} \quad (1.12)$$

For the motion of a particle, the orbital angular momentum of the particle, l , with mass m , relative to the center of mass, is

$$\mathbf{l} = \mathbf{r} \times \mathbf{p} \quad (1.13)$$

\mathbf{l} is a vector of magnitude mvr for circular motion. For motion past a stationary point, the magnitude is $m vb$ where b is the impact parameter. The relationship between a force \mathbf{F} and the potential energy V is generally

$$\mathbf{F} = \frac{-\partial V}{\partial \mathbf{r}} \quad (1.14)$$

Thus, for example, the Coulomb force, F_C , for two charges $Z_1 e$ and $Z_2 e$ separated by the distance, r , is

$$F_C = \frac{Z_1 Z_2 e^2}{r^2} \quad (1.15)$$

where, for convenience, we set $e^2 = 1.439\,98 \text{ MeV fm}$.

1.5.3 Relativistic Mechanics

When a particle moves with a velocity approaching the speed of light, according to the special theory of relativity by A. Einstein, the mass of the particle changes with speed according to

$$m' = \gamma m_0 \quad (1.16)$$

where m' and m_0 are the masses of the particle in motion and at rest and γ is the Lorentz factor

$$\gamma = (1 - \beta^2)^{-1/2} \quad (1.17)$$

and

$$\beta = \left(1 - \frac{1}{\gamma^2}\right)^{1/2}$$

where β is v/c , the velocity of the particle relative to the speed of light. The total energy of a relativistic particle is

$$E = m'c^2 \quad (1.18)$$

this being the kinetic energy, T , plus the rest mass energy equivalent m_0c^2 , where

$$T = (\gamma - 1)m_0c^2 \quad (1.19)$$

For a particle at rest, the total energy is

$$E = m_0c^2 \quad (1.20)$$

For a massless particle such as the photon,

$$E = pc \quad (1.21)$$

where p is the momentum of the photon. The momentum of a relativistic particle is

$$p = \gamma m v \quad (1.22)$$

These equations demonstrate why the units MeV/c^2 for mass and MeV/c for momentum are necessary in nuclear calculations.

To give an example, we calculate the velocity, momentum, and total energy of an ^{40}Ar ion with a kinetic energy of 1 GeV/nucleon . The total kinetic energy is $40 \times 1 \text{ GeV/nucleon} = 40 \text{ GeV} = 40\,000 \text{ MeV}$. The rest mass m_0c^2 is approximately 40 atomic mass units (40 amu) or $(40)(931.5) \text{ MeV}$, see Eq. (3.1), or $37\,260 \text{ MeV}$. Thus, $\gamma = T/m_0c^2 + 1 = 1 + 40\,000/37\,260 = 2.07$. With Eq. (1.17), we obtain $\beta = 0.88$. So the velocity is $0.88c$ or $(0.88)(3 \cdot 10^8 \text{ m s}^{-1}) = 2.6 \cdot 10^8 \text{ m s}^{-1}$. We modify Eq. (1.22) to $pc = mc/(1 - \beta)^{1/2}$ and obtain $(40)(931.5)(0.88)(2.07) = 67.7 \text{ GeV}$, that is, $p = 67.7 \text{ GeV}/c$. The total energy, Eq. (1.18), is $(2.07)(40)(931.5) = 77.3 \text{ GeV}$.

The space–time coordinates x, y, z, t in a stationary laboratory system are, in the special theory of relativity, related to the space–time coordinates in a system moving along the x axis, x', y', z', t' , by

$$\begin{aligned} x' &= \gamma(x - \beta ct) \\ y' &= y \\ z' &= z \\ t' &= \gamma[t - (\beta/c)x] \end{aligned} \quad (1.23)$$

This transformation from the stationary to the moving frame is the Lorentz transformation. The inverse Lorentz transformation is obtained by reversing the sign of v giving

$$\begin{aligned} x &= \gamma(x' + \beta ct') \\ y &= y' \\ z &= z' \end{aligned}$$

$$\begin{aligned}
 t &= \gamma[t' + (\beta/c)x'] \\
 \Delta t &= \gamma[\Delta t' + (\beta/c)\Delta x] \\
 \Delta x &= \Delta x' / \gamma
 \end{aligned}
 \tag{1.24}$$

For $\gamma > 1$, time is slowed down for the scientist in the laboratory, and the distance in the x direction is contracted. An example for the relevance of these equations in nuclear chemistry is the decay of rapidly moving particles such as muons in cosmic rays. At rest, the muon has a lifetime of $2.2 \mu\text{s}$. At relativistic energies such as in cosmic rays, the lifetime is orders of magnitude longer. Due to this time dilatation, muons can reach the surface of the Earth.

A rule of thumb for the decision of whether the classical expressions or the relativistic expressions are to be used is $\gamma \geq 1.1$.

1.5.4 The de Broglie Wavelength

The well-known wave-particle duality says that there is no distinction between wave and particle descriptions of atomic matter; that is, associated with each particle, there is an equivalent description in which the particle is assigned a wavelength, the de Broglie wavelength,

$$\lambda = \frac{h}{p} \tag{1.25}$$

or in rationalized units

$$\lambda = \frac{\hbar}{p} \tag{1.26}$$

with $\hbar = h/2\pi$. The relativistic equivalent is

$$\lambda = \frac{\hbar c}{[E_k(E_k + 2m_0c^2)]^{1/2}} \tag{1.27}$$

Figure 1.8 shows de Broglie wavelengths for a sample of particles (electron, pion, proton, and neutron, deuteron, α particle) as a function of kinetic energy. They are largest for the lightest particles at lowest energies. The horizontal bar indicates the order of magnitude where λ becomes larger than the maximum impact parameter R for light-particle-induced reactions and from where the wavelength of the projectile influences the nuclear reaction *cross-section*, see Chapter 12.

One can also associate a wavelength to photons

$$\lambda = \frac{c}{\nu} = \frac{hc}{E_\gamma} \tag{1.28}$$

where ν is the frequency associated with the wavelength λ . A practical form of Eq. (1.28) is

$$\lambda = \frac{1.2397 \cdot 10^{-10}}{E_\gamma(\text{MeV})} \text{ cm} \tag{1.29}$$

Treating photons as particles is useful if they are emitted or absorbed by a nucleus. Here, we have

$$E_\gamma = h\nu = pc \tag{1.30}$$

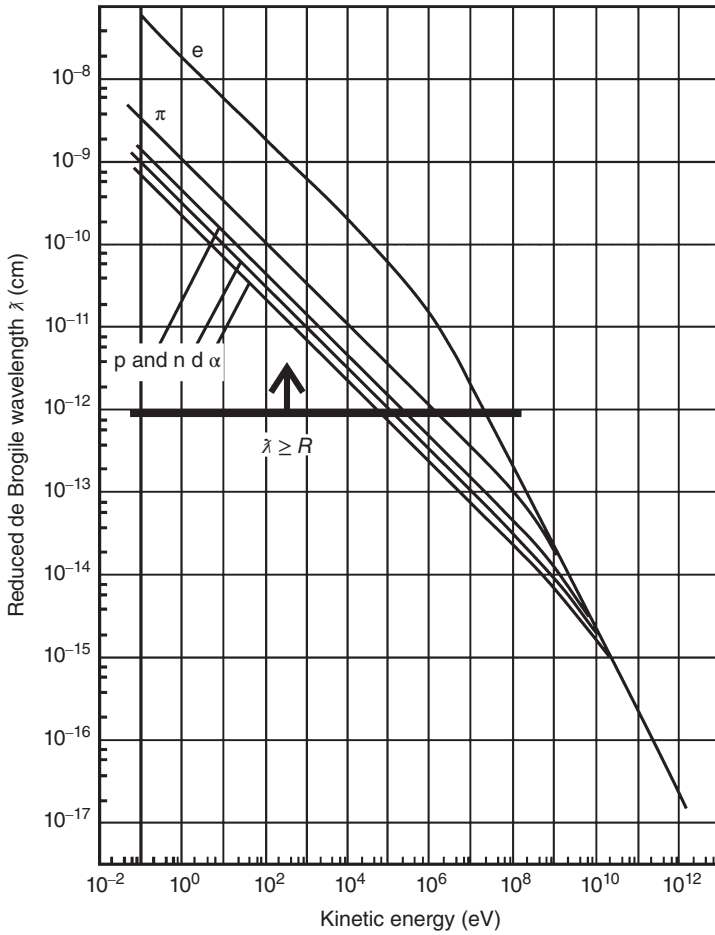

Figure 1.8 De Broglie wavelengths vs. particle kinetic energy for a few particles.

1.5.5 Heisenberg Uncertainty Principle

The Heisenberg uncertainty principle states that there are limits in our knowledge of the location of a particle and its momentum, that is,

$$\Delta p_x \cdot \Delta x \geq \hbar$$

$$\Delta p_y \cdot \Delta y \geq \hbar$$

$$\Delta p_z \cdot \Delta z \geq \hbar$$

$$\Delta E \cdot \Delta t \geq \hbar$$

(1.31)

where $\Delta p_i \cdot \Delta_i$ are the uncertainties in the i th component of the momentum and the location on the i th coordinate, while ΔE is the uncertainty in the total energy of the particle and Δt is its lifetime. These limits are not due to the limited resolution of our instruments; they are fundamental even with perfect instrumentation.

We will encounter a typical application in β decay, in Chapter 6, when it comes to counting the number of ways that the decay energy can be divided between the electron and the neutrino. There, with Eq. (1.31), we will see that the location and momentum of the electron and neutrino are somewhere within the volume of a spherical shell in phase space where the volume of the unit cell is h^3 . The number of states of the electron with momentum between p_e and $p_e + dp_e$ is the volume of a spherical shell in momentum space $4\pi p_e^2 dp_e$. In addition, it must be found in space in a volume V . Together, this gives the phase volume $4\pi p_e^2 V dp_e$. The number of possibilities for the electron to find itself within this phase volume is obtained by normalizing the latter to the volume of the unit cell h^3 , such that

$$dN_e = \frac{4\pi p_e^2 V dp_e}{h^3} \quad (1.32)$$

Similarly for the neutrino, the number of states of the free neutrino with momentum between p_ν and $p_\nu + dp_\nu$ in a volume V is

$$dN_\nu = \frac{4\pi p_\nu^2 V dp_\nu}{h^3} \quad (1.33)$$

and the total number of states $dn = dN_e dN_\nu$ is

$$dn = \frac{16\pi^2 V^2 p_e^2 p_\nu^2 dp_e dp_\nu}{h^6} \quad (1.34)$$

Equation (1.34) will be used in Chapter 6 to deduce the density of final states dn/dE_0 where n is the number of states per unit energy interval, the so-called statistical or phase space factor, which determines the shape of the electron momentum distribution.

1.5.6 The Standard Model of Particle Physics

Figure 1.9 depicts matter as consisting of six types, or “flavors” of quarks – called up, down, charm, strange, bottom, and top – and six light particles, the leptons, electron, muon, and tau and their three neutrino partners. The 12 particles are divided into three families of increasing mass, each family containing two quarks and two leptons. Their properties are included in Figure 1.9. Each particle also has an antiparticle of opposite electric charge. Our familiar protons and neutrons comprise three quarks: two ups and a down, and two downs and an up, respectively. The Standard Model also includes three of the four fundamental forces: the electromagnetic force and the weak and strong interactions. These are carried by exchange particles called intermediate vector bosons (or gauge bosons), that is, the photon, the W and Z bosons, and the exchange boson of the strong force, the gluon.

Particles can be classified as fermions and bosons. Fermions have antisymmetric wave functions and half-integer spins and obey the Pauli principle. Examples for fermions are neutrons, protons, and electrons. Bosons have symmetric wave functions and integer spins. They need not obey the Pauli principle. Examples are photons and the other gauge bosons. Particle groups such as fermions can be further divided into leptons and hadrons such as the proton and the neutron, the

Standard model of elementary particles
3 generations of matter

Quarks	u $\approx 2.2 \text{ MeV}/c^2$ $\frac{2}{3}$ $\frac{1}{2}$ Up	c $\approx 1.28 \text{ GeV}/c^2$ $\frac{2}{3}$ $\frac{1}{2}$ Charm	t $\approx 173.1 \text{ GeV}/c^2$ $\frac{2}{3}$ $\frac{1}{2}$ Top
	d $\approx 4.7 \text{ MeV}/c^2$ $-\frac{1}{3}$ $\frac{1}{2}$ Down	s $\approx 96 \text{ MeV}/c^2$ $-\frac{1}{3}$ $\frac{1}{2}$ Strange	b $\approx 4.18 \text{ GeV}/c^2$ $-\frac{1}{3}$ $\frac{1}{2}$ Bottom
Leptons	e $\approx 0.511 \text{ MeV}/c^2$ -1 $\frac{1}{2}$ Electron	μ $\approx 105.66 \text{ MeV}/c^2$ -1 $\frac{1}{2}$ Muon	τ $\approx 1.7768 \text{ GeV}/c^2$ -1 $\frac{1}{2}$ Tau
	ν_e $< 1.0 \text{ eV}/c^2$ 0 $\frac{1}{2}$ Electron-neutrino	ν_μ $< 0.19 \text{ MeV}/c^2$ 0 $\frac{1}{2}$ Muon-neutrino	ν_τ $< 18.2 \text{ MeV}/c^2$ 0 $\frac{1}{2}$ Tau-neutrino

Force carriers

Vector bosons	g 0 0 1 Gluon	Scalar boson	H $\approx 125 \text{ GeV}/c^2$ 0 0 Higgs-boson
	γ 0 0 1 Photon		
	Z $\approx 91.19 \text{ GeV}/c^2$ 0 1 Z-boson		W $\approx 80.39 \text{ GeV}/c^2$ ± 1 1 W-bosons

Figure 1.9 Fermions (quarks and leptons) and intermediate vector bosons and the scalar Higgs boson in the Standard Model. The bosons are the force carriers of the four fundamental interactions. Each particle is represented in one of the rectangular fields that represent, from top to bottom, the symbol of the particle, its mass (energy equivalent), its electric charge, its spin, and its name.

nucleons. Hadrons interact via the strong interaction, while leptons do not. Both particle types can interact via other forces such as the electromagnetic force. The neutrino partners of the leptons are electrically neutral and have very small rest masses. Their masses are a vital subject of current research, see Chapter 18.

The Higgs boson is an elementary particle within the standard model of elementary particle physics named after the British physicist Peter Higgs. It is electrically neutral, has spin 0, parity +1, a mass of c. $125 \text{ GeV}/c^2$, and disintegrates after c. 10^{-22} seconds into a bottom–antibottom pair, into two W bosons, or a tau–antitau pair, two Z bosons, or two photons, respectively. It belongs to the Higgs mechanism, a theory already suggested in the 1964 *Phys. Rev. Lett.*, after which gauge bosons and fermions, except the Higgs boson itself, receive their mass by interaction with the omnipresent Higgs field.

These letters contained an explanation showing how mass could arise in local gauge theories. Gauge symmetries explain how the strong and electroweak forces arise, but such symmetries forbid vector boson mass terms. The authors showed how gauge symmetries could be spontaneously broken in such a way that the vector bosons of the theory acquire mass. These papers foresaw different aspects of this mechanism. The mechanism predicts the existence of a physical particle, known as the Higgs boson. In 2012, two experiments at the Large Hadron Collider (LHC) at CERN observed the Higgs boson, thus validating the prediction. The 2004 Wolf Prize was awarded to Englert, Brout, and Higgs for their contributions to the theories, and the 2010 APS Sakurai Prize was awarded to Englert, Brout, Higgs, Guralnik, Hagen, and Kibble. The Nobel Prize in Physics for 2013 was awarded to Englert and Higgs.

Since then, the building blocks of the standard model of particle physics let divide themselves into four groups: quarks, leptons, gauge bosons, and the Higgs boson. By the second quantization in physics, the apparent contrast between particles and waves is abolished; a particle is described as excited state of the corresponding quantum field. Thereafter, the Higgs boson corresponds to the quantum mechanical excitation of the Higgs field.

The Higgs boson, a scalar boson, is so important for particle physics because its existence related to the Higgs mechanism is predicted as a solid part of the standard model. The relevant gauge theory requires that the gauge bosons that realize the interaction between other particles are mass-less particles. Indeed, this is realized for the gauge boson of the electromagnetic interaction, the photon, and for the gauge bosons of the strong interaction, the gluons. For the gauge bosons of the weak interaction, the W- and Z-bosons, however, this is not the case. These have relatively large masses, which cause the small range, let the “weak interaction” appear so weak relatively to the electromagnetic interaction.

The Higgs mechanism shows that the mass-less W- and Z-bosons in the original equation of the theory appear in all further developed equations as particles of a certain mass. To this end, one has to let them interact with a further physical field, the Higgs field. This way, the Higgs mechanism allows one to come up with a fundamental gauge theory in which the electromagnetic and the weak interaction are unified to the electroweak interaction. By their interaction with the Higgs field, also the other masses of the elementary particles, properties that were seen before as originally

fixed, are now being interpreted as a consequence of a new kind of interaction. Only the origin of the Higgs mass itself withdraws itself from this point of view, it remains further unexplained.

Outside the standard model of elementary particles, Figure 1.9 contains another force carrier related to the gravitational force, the hypothetical gravitons, which have never been observed. The classical gravitational force as proposed by Isaac Newton is a radial field produced by mass

$$F = G \cdot \frac{m_1 \cdot m_2}{r^2} \quad (1.35)$$

with the gravitational constant $G = 6.67408 \cdot 10^{-11} \text{ m}^3 \text{ kg}^{-1} \text{ s}^{-2}$. From this follows that the gravitational velocity on the earth's surface is the well-known earth gravitational acceleration $g = 9.81 \text{ m s}^{-2}$. The ratio of the gravitational force to the electromagnetic force is 10^{-36} . Albert Einstein, in his "Allgemeine Relativitätstheorie," has seen this completely different: mass distorts space and time, the resulting gravitation is a distortion of the four-dimensional spacetime that also bends light as observed for the first time on the occasion of the total solar eclipse observed on 29 May 1919. Einstein also predicted that accelerated masses produce gravitational waves. A gravitational wave is a wave in the spacetime that is caused by accelerated mass. According to relativity theory, nothing can move faster than with the speed of light. Therefore, local changes in the gravitational field can affect distant locations only after a finite time. From this, Einstein in 1916 proposed the existence of gravitational waves. When crossing a section of space, certain distances get intermediately shrunk and stretched within the segment of space. This can be viewed as shrinkage and stretching of the space itself. As in the Newtonian gravitational theory, modifications of the sources of the gravitational field have consequences for the entire space without delay; it does not know gravitational waves. On 11 February 2016, researchers of the LIGO collaboration reported on first successful direct measurements of gravitational waves in September 2015, which were produced in the collision of two black holes. For this, in 2017, Rainer Weiss, Barry Barsh, and Kip Thome were awarded the Nobel prize in Physics.

In gravity, mass is what is the charge in electromagnetism. Other than for the electrical charge, a negative mass is not known. Therefore, dipoles of masses do not exist. Without dipoles, there cannot be dipole radiation. However, accelerated masses lead to quadrupolar radiation. The multipole expansion of the gravitational field of two circulating stars contains as lowest order the quadrupolar radiation. In a quantum field theoretical perspective in the gravitational interaction, the related gauge boson is the hypothetical graviton, a spin 2 particle in analogy to the spin 1 photon in the quantum electrodynamics. However, a formulation of the gravitation without contradictions on this basis is so far not available,

A final remark related to Figure 1.9 concerns the neutrinos, and in particular their masses. Section 18.5 of this textbook is devoted to the "Mystery of the Missing Solar Neutrinos" and its solution, which has provided a clue to physics beyond the Standard Model of particle physics. That is solid evidence for neutrino-mass fluctuations, i.e. a detector that is sensitive only to one neutrino flavor sees intensity fluctuations as a function of the mixing angle, the quadratic mass difference between

the fluctuating mass eigenstates, the distance between the source and the detector, and the neutrino kinetic energy.

In nuclear processes involving leptons, their number must be conserved. For example, in the decay of the free neutron

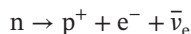

the number of leptons on the left is zero, so the number of leptons on the right must be zero as well. We see that this is true if we assign a lepton number $L = 1$ to the electron and $L = -1$ to the $\bar{\nu}_e$ being an antiparticle. For the reaction

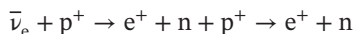

which was instrumental in the discovery of the antineutrino by F. Reines and C. Cowan in 1959, $L = -1$ on both sides, and lepton conservation is fulfilled as well. As for leptons, there is a conservation law for baryons. To each baryon, we assign a baryon number $B = +1$ and $B = -1$ to each antibaryon. The total baryon number must be conserved. Take for example the reaction

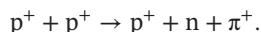

On both sides, we have $B = 2$ because the π^+ is a meson with $B = 0$. Since three quarks/antiquarks binding together make baryons/antibaryons, binding a quark with an antiquark forms mesons. The π^+ and π^- ($u\bar{d}$, $d\bar{u}$) mesons are important particles in nuclear chemistry. Mesons have integer spins and are bosons. Some mesons and baryons are listed in Table 1.3. All mesons are unstable with lifetimes up to about 10^{-8} seconds. The baryons are also unstable, with the exception of the neutron (lifetime 885.7 seconds) and the proton, which is considered to be stable.

A set of symmetries that are a sensitive probe of the Standard Model describe what happens if certain particle properties are reflected as though in a mirror. There is a charge mirror (C) changing particles into antiparticles of opposite charge, a parity mirror (P) changing the spin or handedness of a particle, and a time mirror (T) reversing a particle interaction, like rewinding a video. Surprisingly, these mirrors do not work perfectly. β particles emitted in the decay of ^{60}Co always spin in the same direction even if the spin of the cobalt nucleus is reversed. Cracks in the C and P mirrors (CP violation) also appear in the decay of exotic mesons – the kaon and the B meson. Connected to CP and T violation is the existence of permanent electric dipole moments (EDMs) in particles such as the neutron and atoms. EDMs are forbidden by P, T, and CP symmetries, but might be essential to explain the predominance of matter over antimatter in the Universe. Laboratories worldwide are actively searching for these EDMs. This is typical of high-precision measurements using nuclear particles at lowest energies to search for physics beyond the Standard Model. This way, nuclear chemists are actively involved in furthering our knowledge of fundamental interactions and symmetries.

1.5.7 Force Carriers

In Section 1.5.1, we introduced the force carriers, which are all bosons. In Section 1.5.5, we dealt with the Heisenberg uncertainty principle. Together, these

Table 1.3 Examples for hadrons.

Symbol	Quark composition	Mass (GeV/c ²)	Mean lifetime (s)
<i>Mesons</i>			
π^+	$\bar{d}u$	0.140	$\approx 2 \cdot 10^{-8}$
π^0	$\bar{u}u$ or $\bar{d}d$	0.135	$\approx 1 \cdot 10^{-16}$
π^-	$\bar{u}d$	0.140	$\approx 2 \cdot 10^{-8}$
ρ^+	$\bar{d}u$	0.776	
ρ^0	$u\bar{u}$ or $d\bar{d}$	0.770	
ρ^-	$\bar{u}d$	0.776	
K^-	$\bar{u}s$	0.493	$\approx 1 \cdot 10^{-8}$
K^0	$d\bar{s}$	0.498	$\approx 0.9 \cdot 10^{-10}$ to $5 \cdot 10^{-8}$
K^+	$u\bar{s}$	0.493	$\approx 1 \cdot 10^{-8}$
B^-	$u\bar{b}$	5.271	$\approx 1 \cdot 10^{-12}$
B^0	$d\bar{b}$	5.275	$\approx 1 \cdot 10^{-12}$
<i>Baryons</i>			
N	udd	0.9396	885.7
P	uud	0.9383	Stable
Λ	uds	1.116	$\approx 2 \cdot 10^{-10}$
Σ^+	uus	1.190	$\approx 1 \cdot 10^{-10}$
Σ^0	uds	1.192	$\approx 1 \cdot 10^{-14}$
Ξ^-	dss	1.322	$\approx 2 \cdot 10^{-10}$
Ω^-	sss	1.672	$\approx 1 \cdot 10^{-10}$

will allow us now to understand how force carriers work. For illustration, let us consider the electromagnetic force between two positively charged particles. The latter is caused by photons passing between them. One tends to think that the emission of a photon should change the energy of the emitter, but exchange of a force carrier does not. The solution is that the uncertainty principle allows the emission of virtual particles if such emission and absorption occur within a time Δt that is less than that allowed by the uncertainty principle, Eq. (1.31), saying that $\Delta t = \hbar/\Delta E$, where ΔE is the extent to which energy conservation is violated. We will come back to this in Chapter 6.

Reference

General and Historical

Geiger, H. and Marsden, E. (1913). The laws of deflexion of α particles through large angles. *Philos. Mag.* 25: 604.

Further Reading

General and Historical

- Rutherford, E. and Soddy, F. (1902). The cause and nature of radioactivity I, II. *Philos. Mag.* 4 (370): 569.
- Rutherford, E. and Soddy, F. (1903). Radioactive change. *Philos. Mag.* 5: 576.
- Geiger, H. and Marsden, E. (1909). On a diffuse reflection of the α particle. *Proc. R. Soc. London, Ser. A* 82: 495.
- Rutherford, E. (1911). The scattering of α and β particles by matter and the structure of the atom. *Philos. Mag.* 21: 669.
- Moseley, H.G. (1913). The high-frequency spectra of the elements I. *Philos. Mag.* 26: 1024.
- Moseley, H.G. (1914). The high-frequency spectra of the elements II. *Philos. Mag.* 27: 703.
- Evans, R. (1955). *The Atomic Nucleus*. New York: McGraw-Hill.
- Romer, A. (1964). *The Discovery of Radioactivity and Transmutation*. New York: Dover.
- Harvey, B.G. (1965). *Nuclear Chemistry*. Englewood Cliffs, NJ: Prentice Hall.
- Harvey, B.G. (1969). *Introduction to Nuclear Physics and Chemistry*, 2e. Englewood Cliffs, NJ: Prentice Hall.
- Romer, A. (1970). *Radiochemistry and the Discovery of Isotopes*. New York: Dover.
- Harvey, B.G. and Evans, R. (1971). *The Atomic Nucleus*. New York: McGraw-Hill.
- Friedlander, G., Kennedy, J., Macias, E.S., and Miller, J.M. (1981). *Nuclear and Radiochemistry*, 3e. New York: Wiley.
- Seaborg, G.T. and Loveland, W. (1982). *Nuclear Chemistry*. Stroudsburg, PA: Hutchinson-Ross.
- Ehmann, W.D. and Vance, D.E. (1991). *Radiochemistry and Nuclear Methods of Analysis*. New York: Wiley.
- Loveland, W. (1992). Nuclear chemistry. In: *Encyclopedia of Physical Science and Technology*, vol. 11. Orlando, FL: Academic Press.
- Adloff, J.P., Lieser, K.H., and Stöcklin, G. (eds.) (1995) One hundred years after the discovery of radioactivity. *Radiochim. Acta* 70/71 (special issue).
- Choppin, G.R., Liljenzin, J.O., and Rydberg, J. (2001). *Radiochemistry and Nuclear Chemistry*, 3e. Oxford: Butterworth-Heinemann.
- Fényes, T. (2011). Basic properties of the atomic nucleus. In: *Handbook of Nuclear Chemistry*, 2e, vol. 1 (eds. A. Vértes, S. Nagy, Z. Klencsár, et al.), 39. Berlin: Springer-Verlag.

More Specialized

- Einstein, A. (1918). Über Gravitationswellen, Königlich Preußische Akademie der Wissenschaften (Berlin), *Sitzungsberichte, Mitteilung vom 31.01.1918*, S. 154.
- Englert, F. and Brout, R. (1964). Broken symmetry and the mass of gauge vector mesons. *Phys. Rev. Lett.* 13: 321.
- Guralnik, G.S., Hagen, C.R., and Kibble, T.W.B. (1964). Global conservation laws and massless particles. *Phys. Rev. Lett.* 13: 585.

- Higgs, P.W. (1964). Broken symmetries and the masses of gauge bosons. *Phys. Rev. Lett.* 13: 508.
- Weinberg, S. (1967). A model of leptons. *Phys. Rev. Lett.* 19: 1264.
- Salam, A. (1968). *Elementary Particle Theory* (ed. N. Svartholm), 367. Stockholm: Almquist and Wiksell.
- Marmier, P. and Sheldon, E. (1969). *Physics of Nuclei and Particles*, vol. I and II. New York: Academic Press.
- Glashow, S.L., Iliopoulos, J., and Maiani, L. (1970). Weak interactions with lepton-hadron symmetry. *Phys. Rev. D* 2: 1285.
- Weinberg, S. (1972). Mixing angle in renormalizable theories of weak and electromagnetic interactions. *Phys. Rev. D* 5: 1962.
- Segre, E. (1977). *Nuclei and Particles*, 2e. Reading, MA: Benjamin.
- Musiol, G., Ranft, J., Reif, R., and Seeliger, D. (1988). *Kern- und Elementarteilchenphysik*. Weinheim: VCH Verlagsgesellschaft.
- Frauenfelder, H. and Henley, E.M. (1991). *Subatomic Physics*, 2e. Englewood Cliffs, NJ: Prentice Hall.
- Donoghue, J.F. (1994). *Dynamics of the Standard Model*. Cambridge: Cambridge University Press.
- Weinberg, S. . *The Quantum Theory of Fields*. Cambridge: Cambridge University Press. 1995, 2005
- Heyde, K. (1999). *Basic Ideas and Concepts in Nuclear Physics*. Bristol: IOP Publishing.
- Amsler, C. et al. (Particle Data Group) (2008). The review of particle physics. *Phys. Lett. B* 667: 1.
- Horváth, D. (2011). The standard model of elementary particles. In: *Handbook of Nuclear Chemistry*, 2e, vol. 1 (eds. A. Vértes, S. Nagy, Z. Klencsár, et al.), 457. Berlin: Springer-Verlag.
- ATLAS Collaboration (2012). Observation of a new particle in the search for the standard model Higgs Boson with the ATLAS detector at the LHC. *Phys. Lett. B* 716: 1.
- CMS Collaboration (2012). Observation of a new boson at a mass of 125 GeV with the CMS experiment at LHC. *Phys. Lett. B* 716: 30.
- Abbott, B.P. et al. (2016). Observation of gravitational waves from a 22-solar-mass binary black hole coalescence. *Phys. Rev. Lett.* 116: 241103.